Stealth Antennas

Carl Foster KB7AZ
kb7az@arri.net

The HOA Problem



Stealth Antenna Methods

- **Invisible wire**
 - **Very small wire**
 - **Color that blends in with background**
 - **Good for dipoles and long wire antennas**
- **Camouflage**
 - **Paint**
 - **Decorate with fake leaves**
- **Hidden**
 - **In attic**
 - **Under eaves**
 - **Plain Sight**
 - **Flagpole**
 - **Plumbing vent**

What Prying Eyes Can See

- The human eye can resolve approximately 0.0035 inches at one foot
- At 25 feet, the human eye can resolve 0.0875 inches
- At 50 feet, the human eye can resolve 0.175 inches

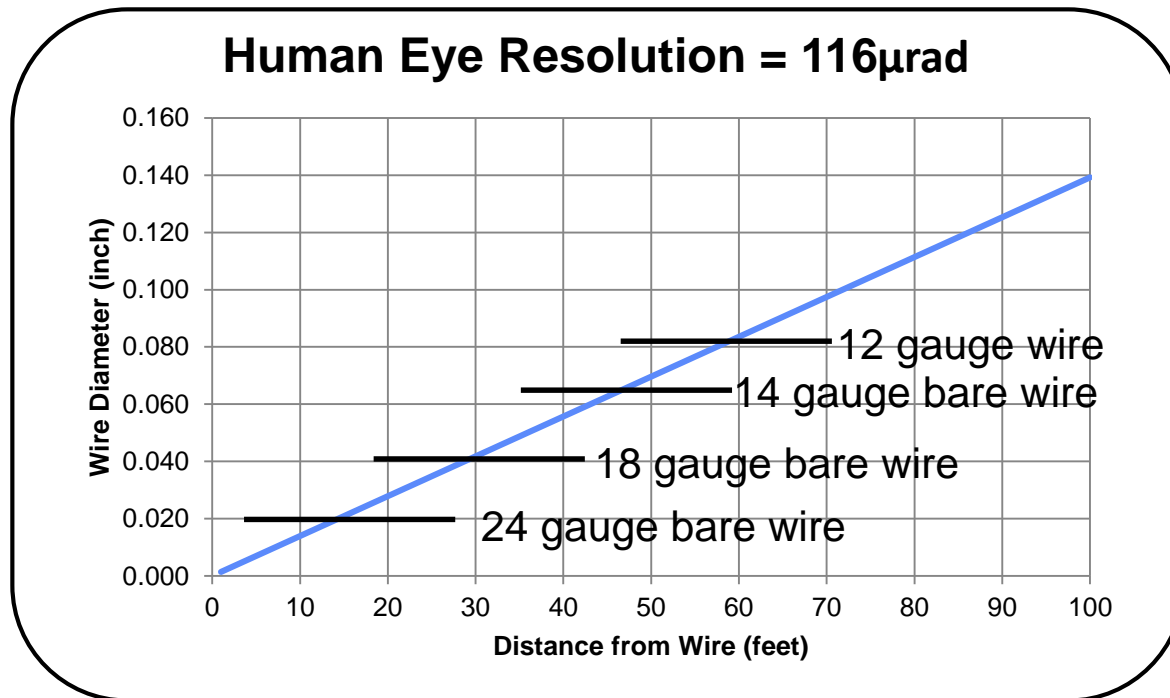

Invisible Wire Dipole

- **Bare copper wire diameters**
 - 12 gauge = 0.0808”
 - 14 gauge = 0.0641”
 - 16 gauge = 0.0508”
 - 18 gauge = 0.0403”
 - 24 gauge = 0.0201”
- **Advantages**
 - Cheap
 - Hard to see
- **Disadvantages**
 - Narrow bandwidth
 - Small capture area

Silver Plated Stainless Steel Wire

- Beading wire for pearl necklaces
- Nylon and silver-plated stainless steel, clear, 49 strand, 0.024-inch diameter (approximately 24 gauge)
- Sold in 30-foot and 100-foot spools
- Tensile strength > 50 pounds



Antenna wire from “The Wireman”

- www.thewireman.com
- **Product 532**
 - **Stranded, coated antenna wire 18 AWG (OD 0.0445") "Silky" 40% copper-clad steel conductor, nominal OD, 0.090" including 0.020" jacket, breaking strength 125 lbs. (approximately \$0.20/foot)**
- **Product 534 (New Product)**
 - **'Invisible' Toughcoat 'Silky' 26 AWG, 19 strand 40% copper-clad steel (OD 0.020"), nominal OD 0.050" including 0.015" jacket**
 - **Super small for a 'low profile' antenna or pocket 'weekender' long wire, weighs less than one pound per 1000 feet, not recommended for 160 meters, breaking strength 25 lbs. (approximately \$0.20/foot)**

Skin Effect

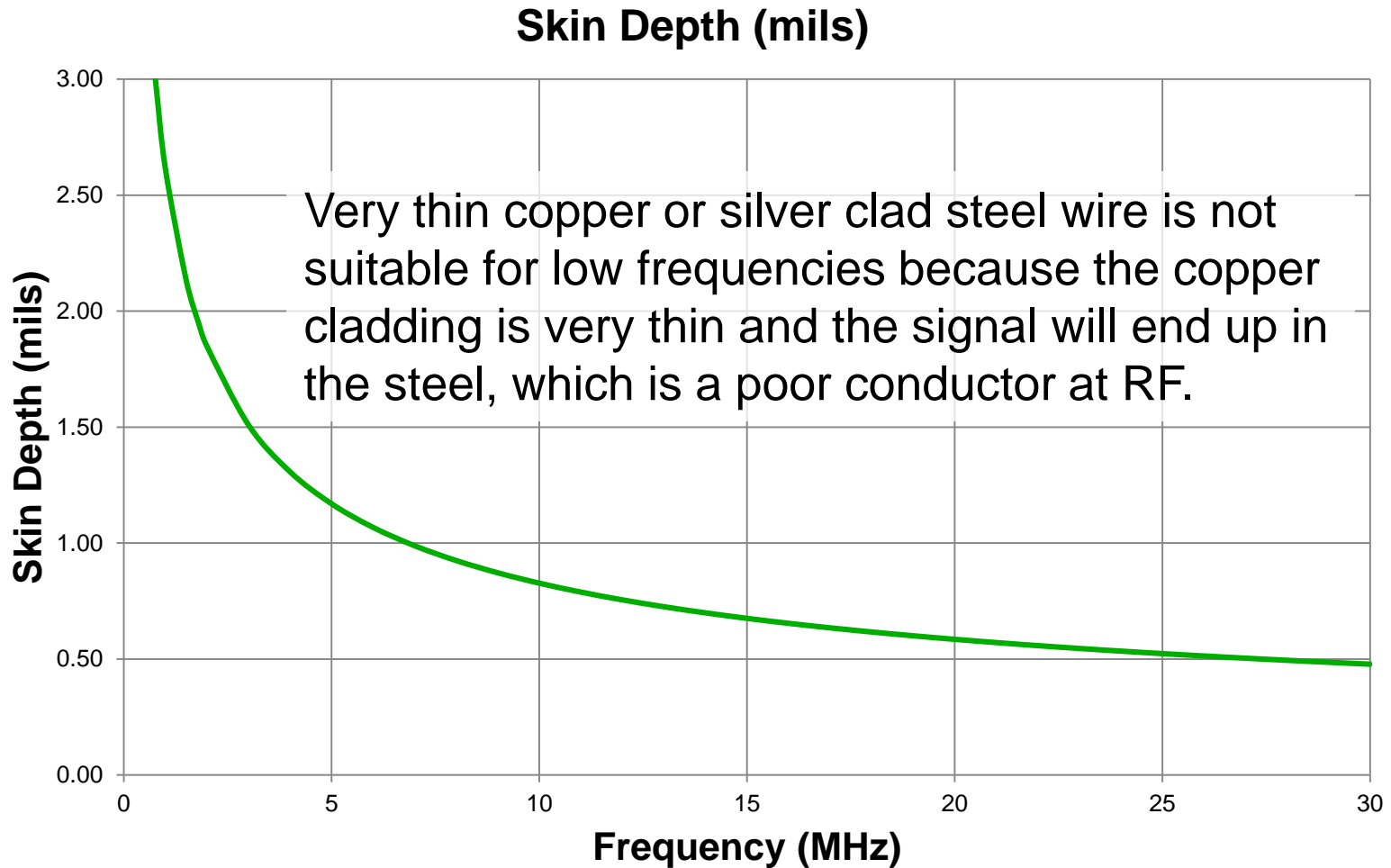

Large Diameter Dipole

1" Diameter pipe

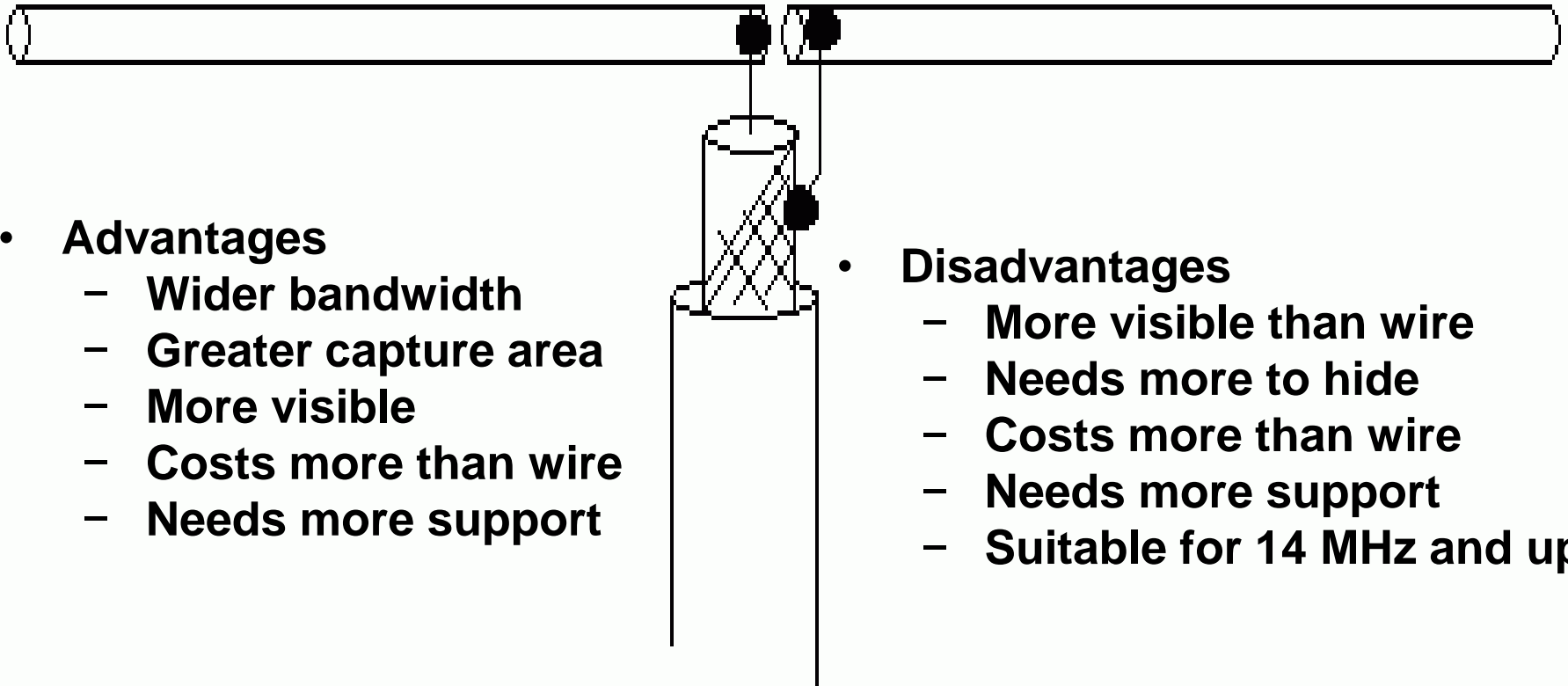

- **Advantages**

- Wider bandwidth
- Greater capture area
- More visible
- Costs more than wire
- Needs more support

- **Disadvantages**

- More visible than wire
- Needs more to hide
- Costs more than wire
- Needs more support
- Suitable for 14 MHz and up

Folded Dipole Antenna

- **Advantages**
 - Wider bandwidth
 - Lower noise
- **Disadvantages**
 - Requires spreaders
 - Requires 4:1 balun
 - More to hide

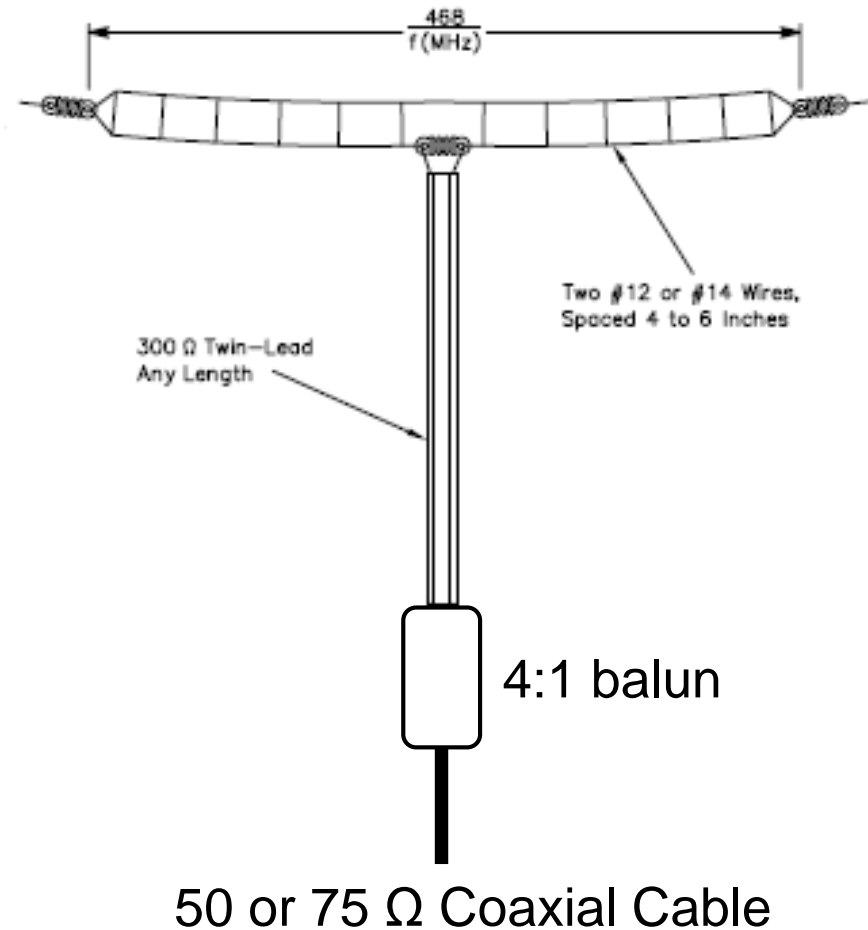

Disguising Antennas



Flat Roof Options

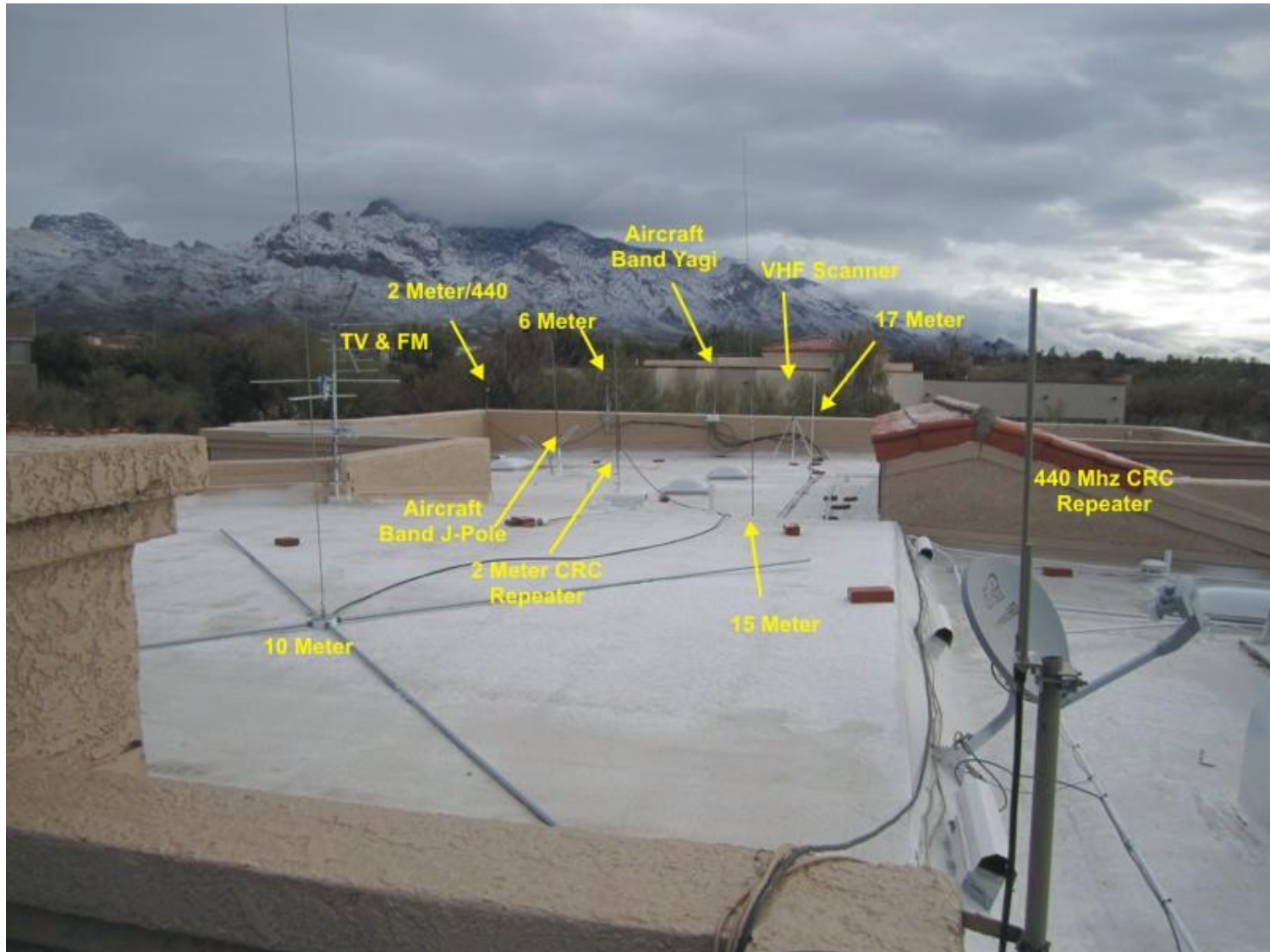

Paint Options

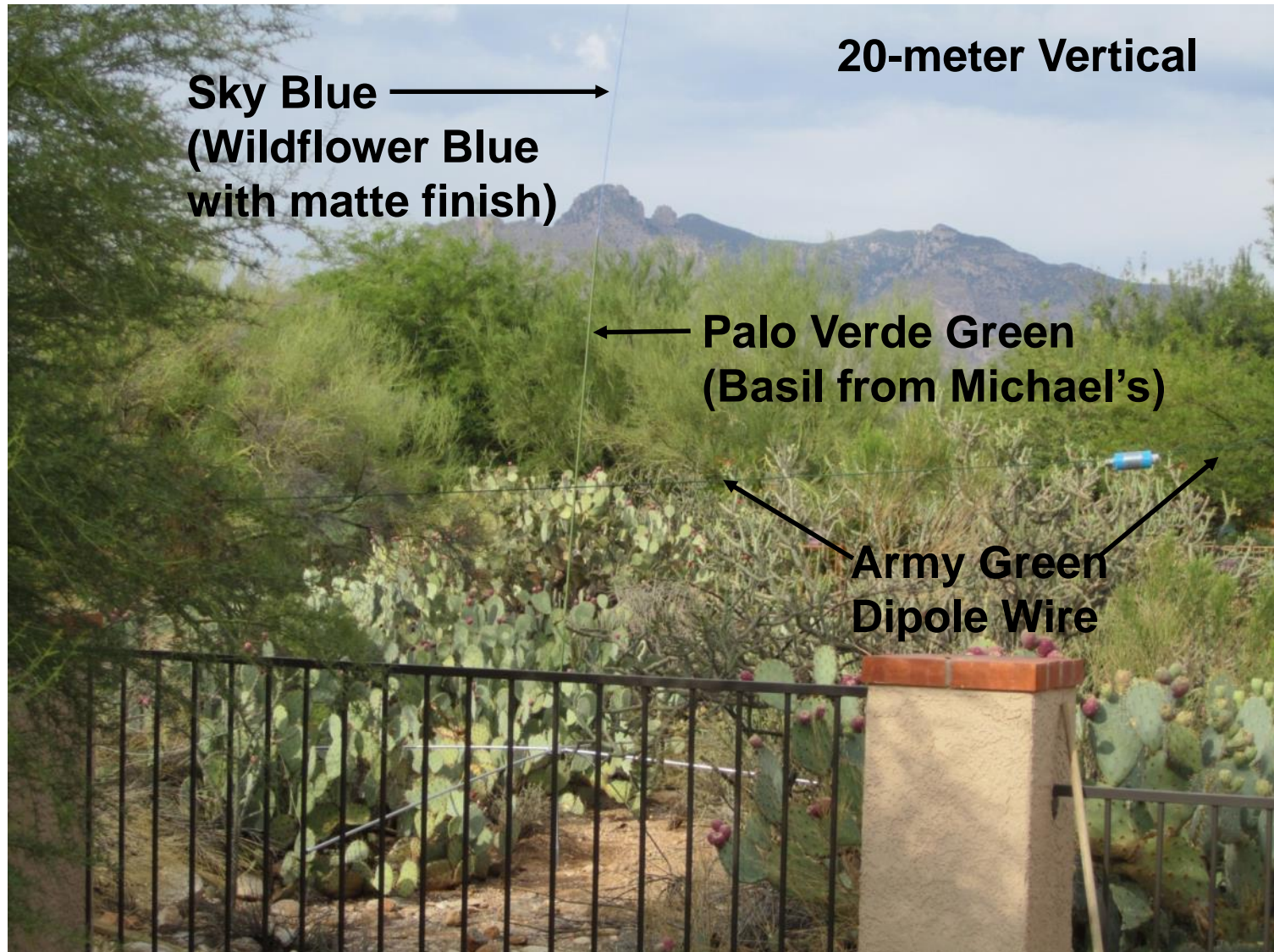

Another View of 20-m Vertical

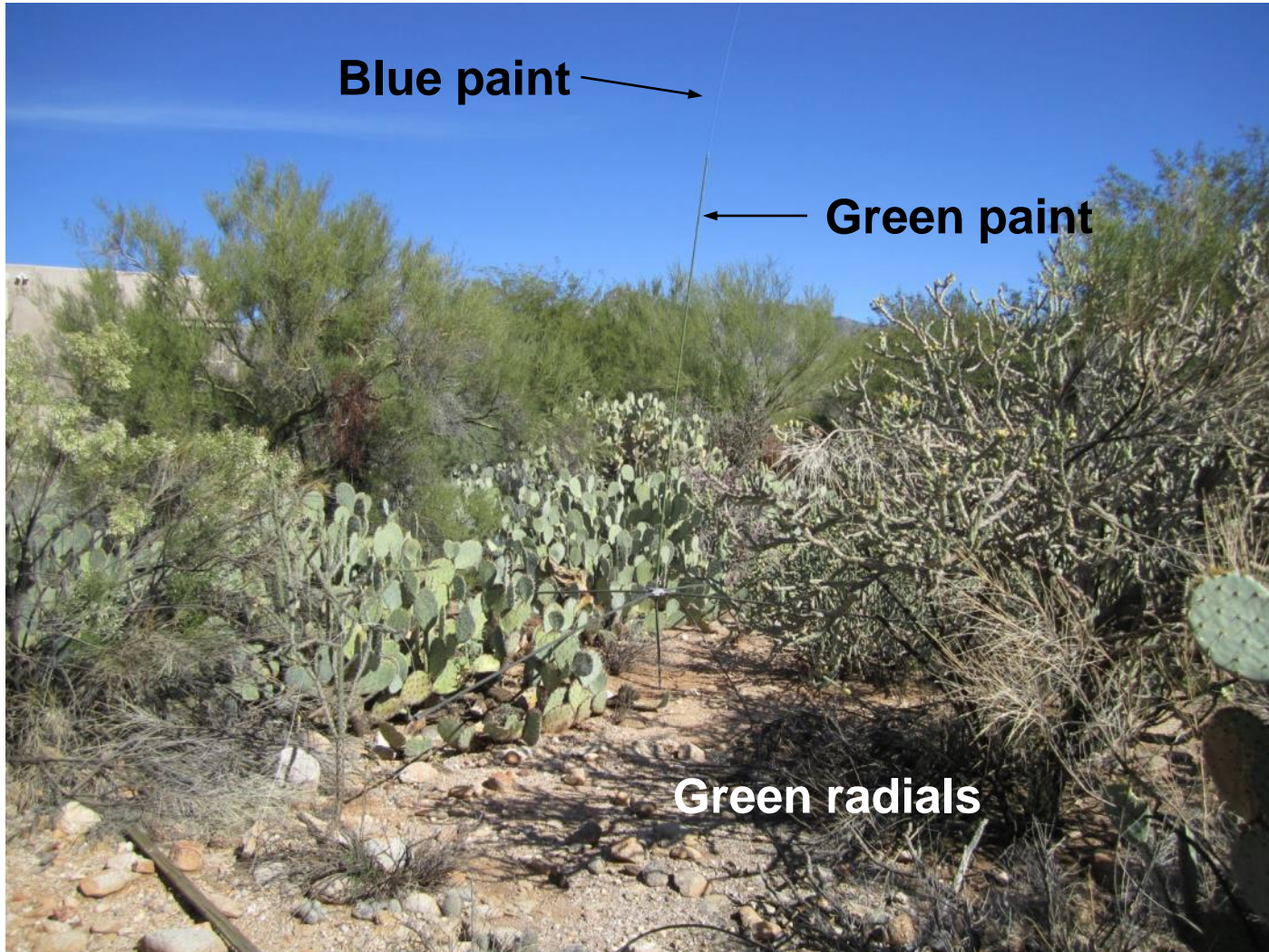

Antenna Base

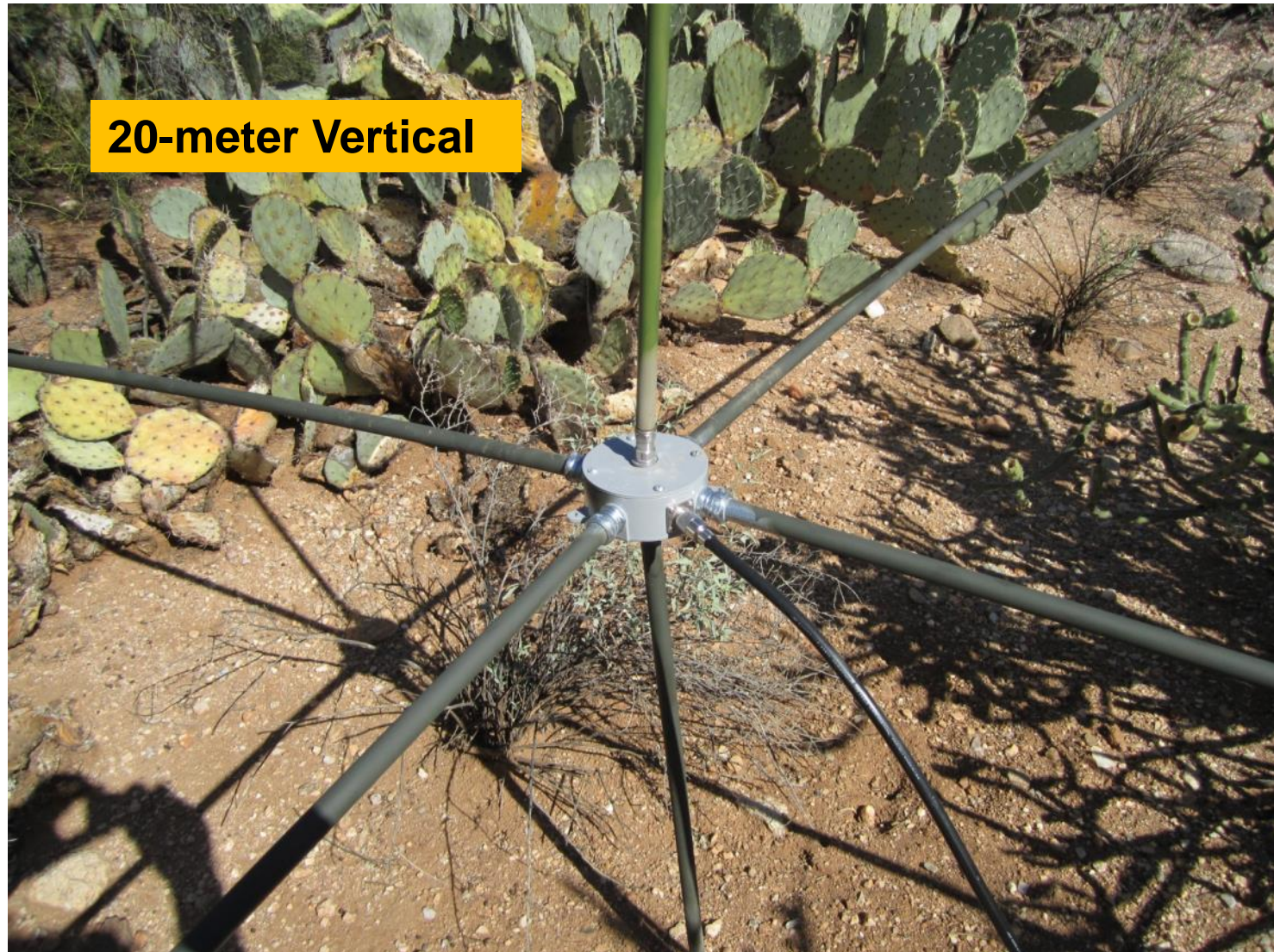

Neutral Grey Paint



Camouflage Paints



Camouflage paint has very low reflectivity, which keeps reflections down while blending into the background

Color Matching

- Various green paint colors are available at Michael's in the floral arranging section
- Rust-oleum Willflower Blue matte finish matches a clear sky



Stealth 2-meter J-pole

- <http://www.hamuniverse.com/jpole.html>
- For 146.62 MHz
 - A = 57.72", 1.466 m
 - B = 19.2" 0.488 m
 - C = 1.92", 49 mm
 - D = 1.8", 46 mm
- Material is 1/2-inch copper pipe
- Inside (spacing) dimensions are metal-to-metal, NOT center--to center.

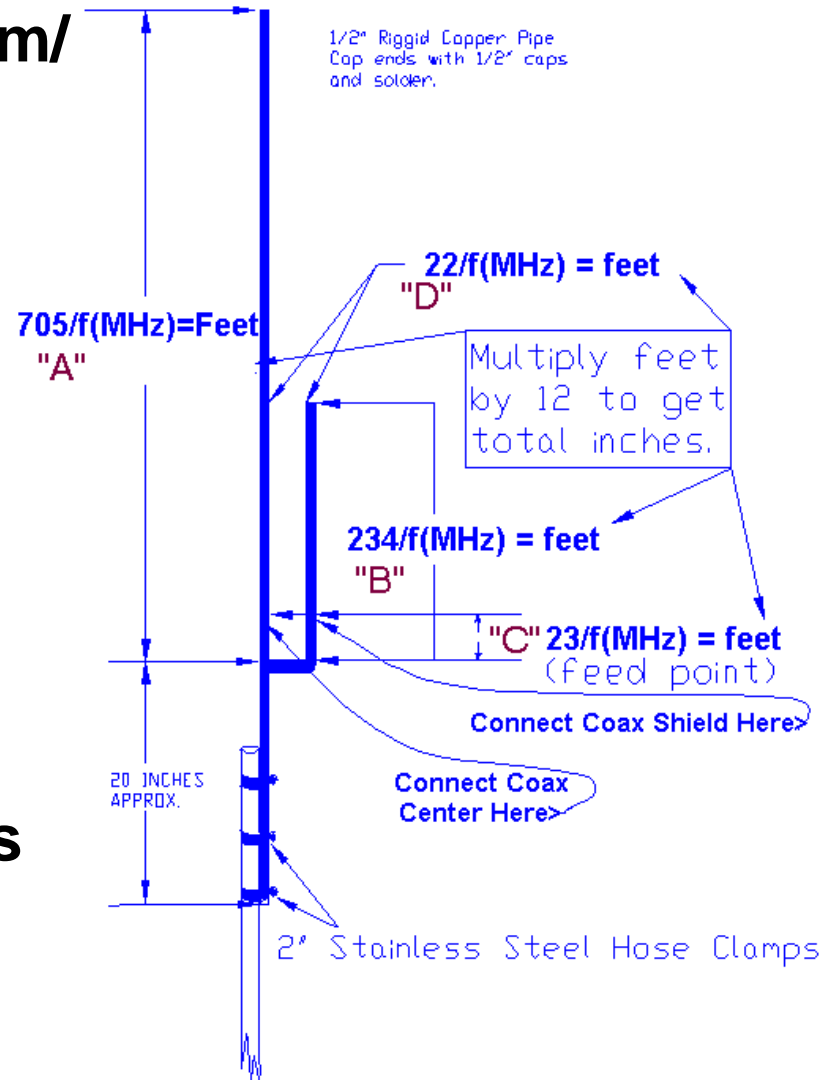

Pre-assembly



Adding Camouflage



2-meter J-pole

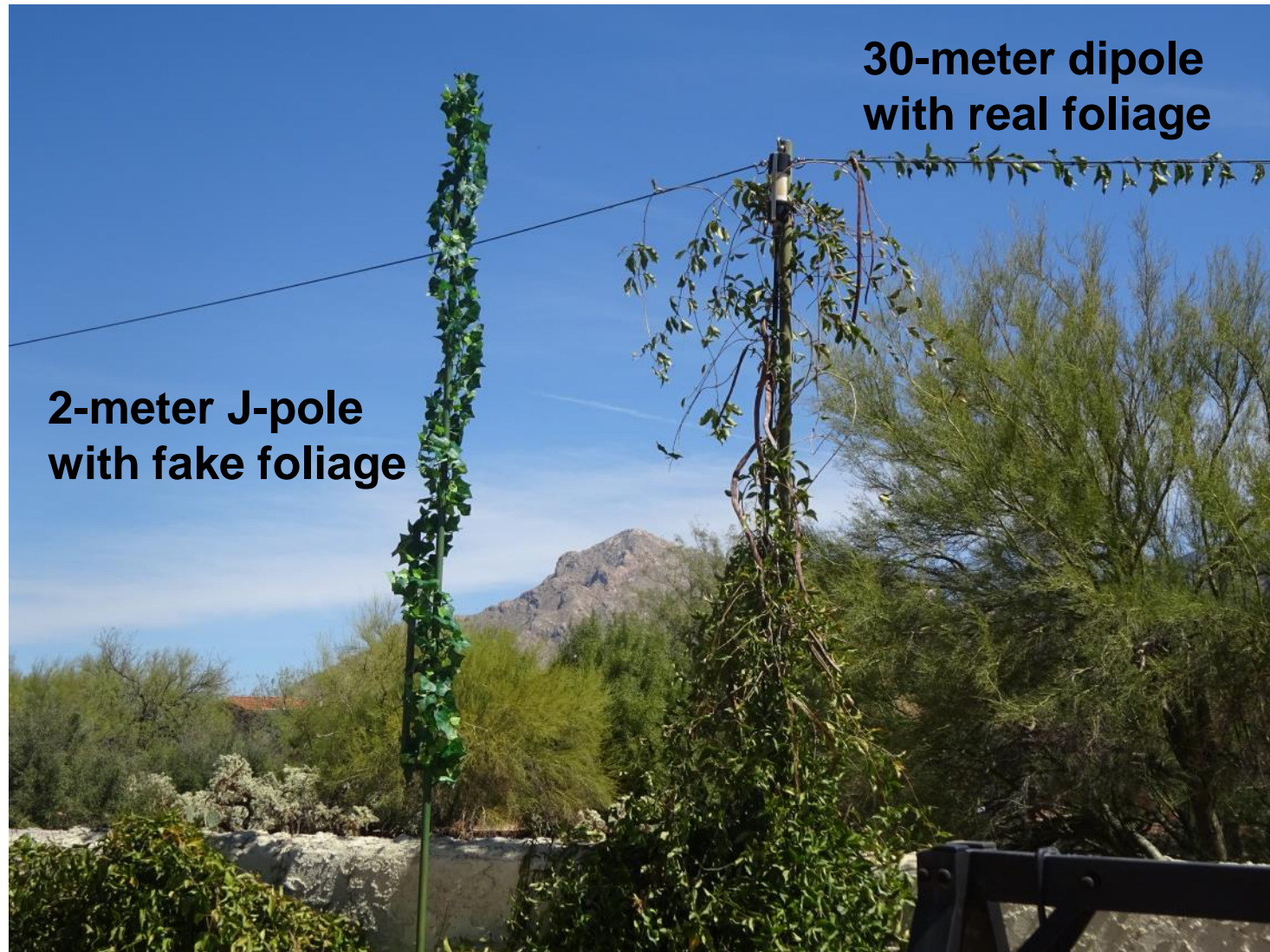

**2-meter J-pole
with fake foliage**

**30-meter dipole
with real foliage**

J-pole Camouflage



Fence Sections

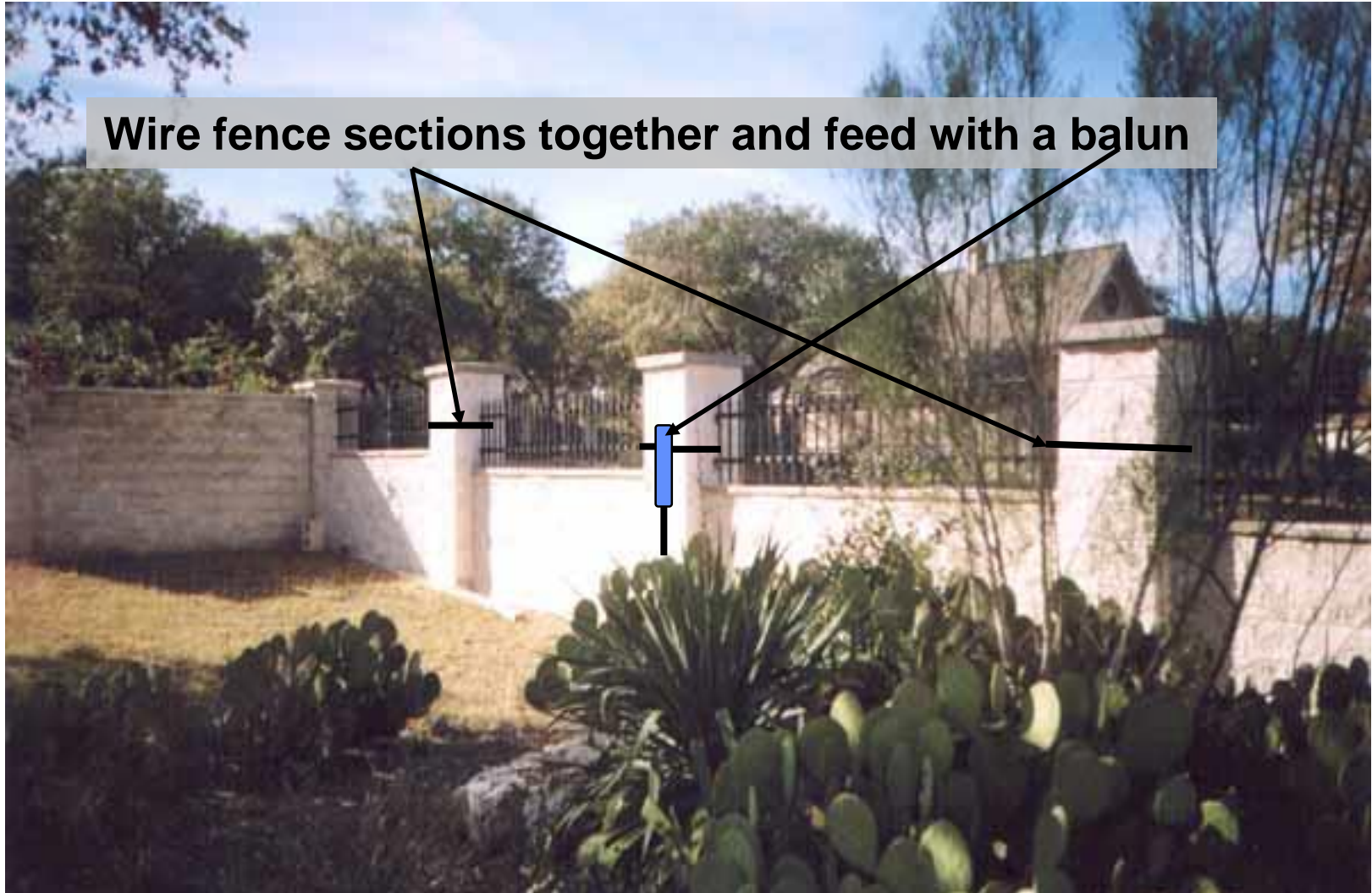

Commercially Available VHF Antenna

- Ventenna is a commercially available antenna that is disguised as a plumbing vent pipe
- It can also be used as a birdhouse mount
- <http://www.ventenna.com>



Plumbing Vent Ideas

- **Plumbing vent pipes extend from above a sink connection to a drainpipe to above the roof.**
- **Except for water vapor and rain water, the vent is dry.**
- **Vent pipes are usually very close to the drywall.**
- **A Ventenna can be connected using the vent pipe.**

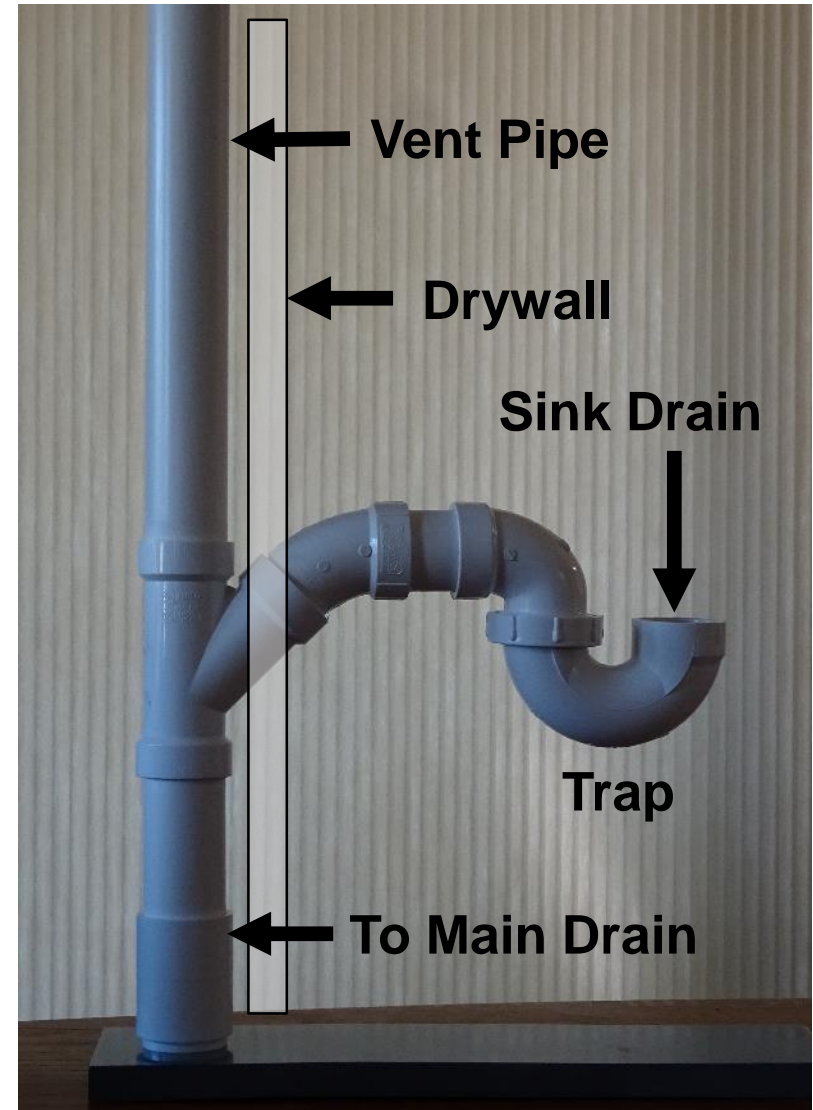

Drill a Hole for Coaxial Cable

- **Drill a hole above the sink drain connection**

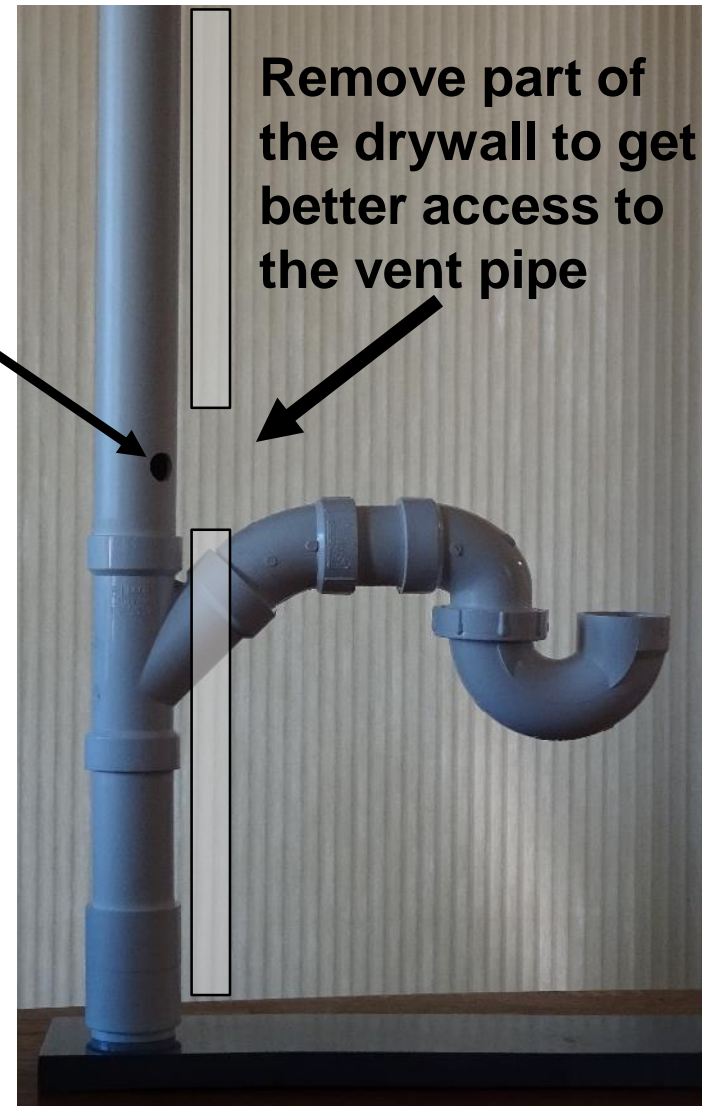
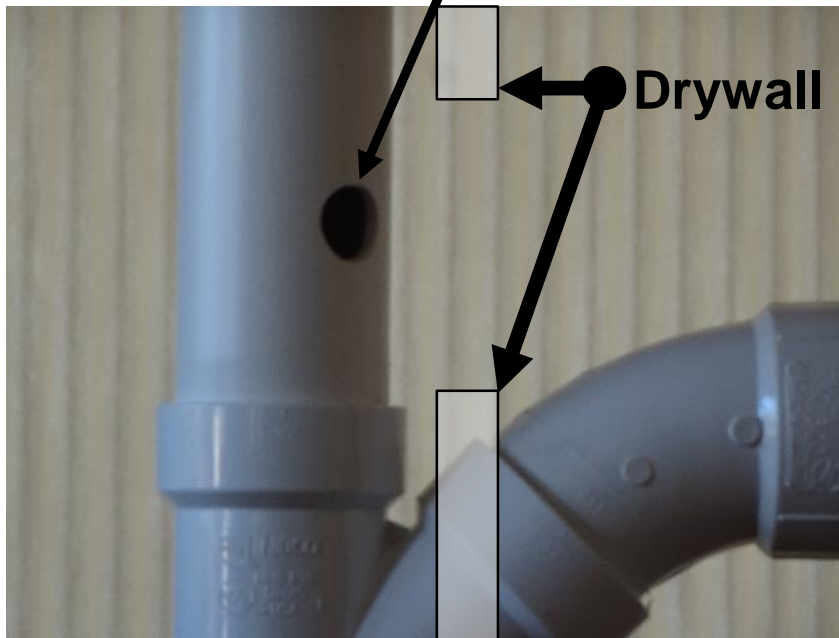

Run Coaxial Cable up to Roof

- **5/8-inch hole for BNC**
- **1-inch hole for PL-259**

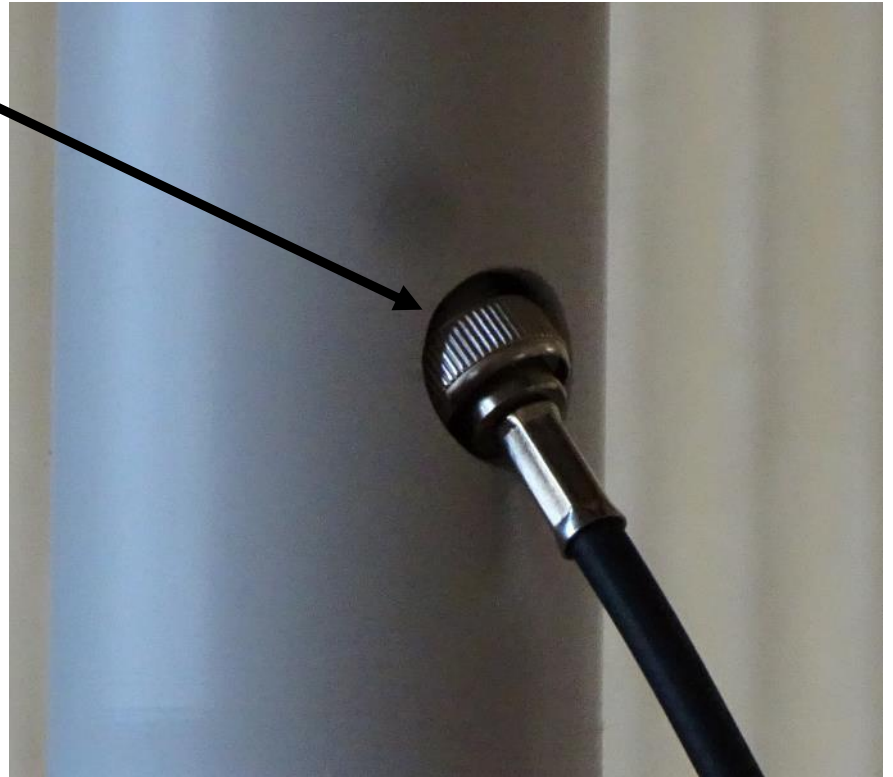

Coaxial Cable Vertical Dipole

- Strip cable outer coating
- Fold woven shield back
- Tune to desired frequency
- Push up the vent pipe until the tip is almost sticking out of the top
- Use sealant around the hole to keep odors from escaping
- The purpose of the trap is to keep odors from coming up through the sink drain

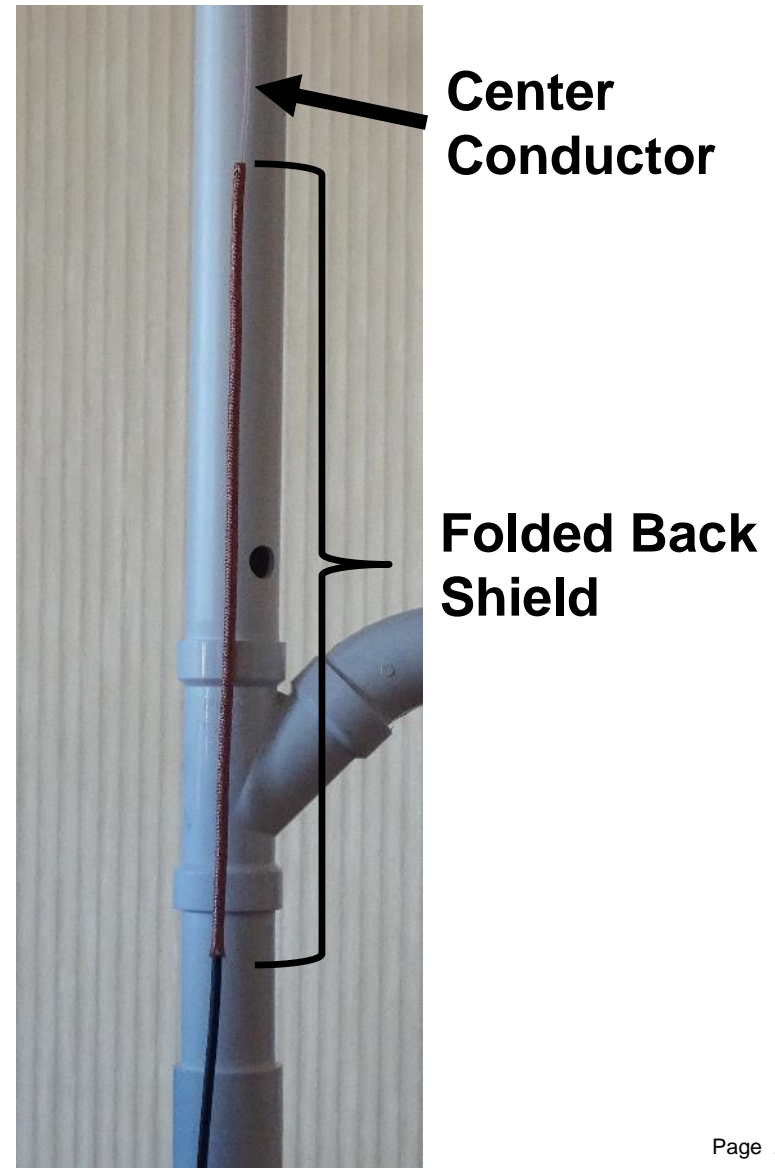

Satellite Dish 2-meter Antenna

- Details in the March 2016 QST
- Made from a standard satellite dish antenna



Attic Antennas



More Attic Antennas



Large Diameter Attic Antenna



“Slinky” Antenna

Keep away from wood to avoid arcing, especially at ends

Remote Antenna Tuner

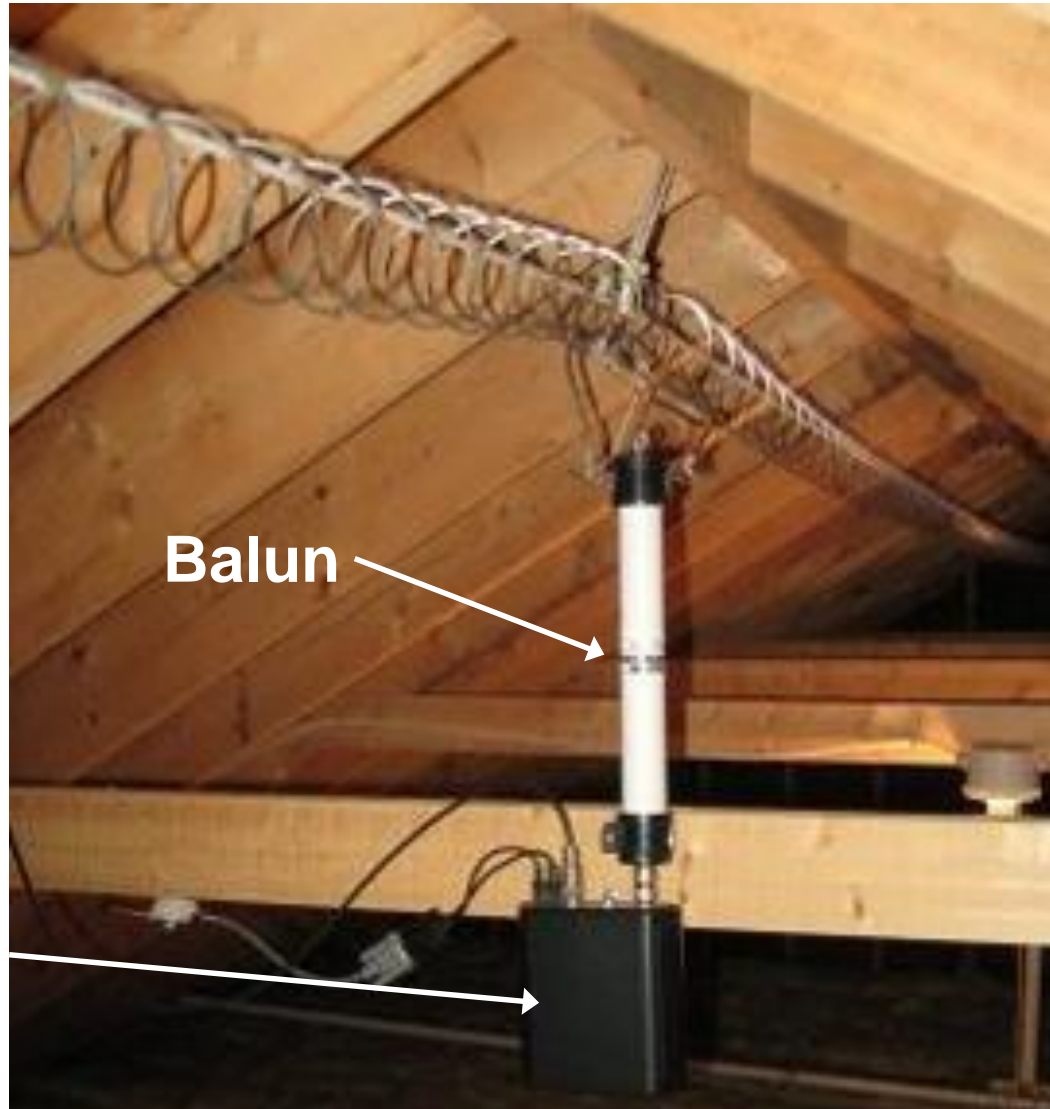

Dryer Vent Antenna

**NO, HONEY, IT IS NOT
ANOTHER ANTENNA.**



**I'M INSTALLING A VENT FOR
THE DRYER IN THE ATTIC!**

Attic Antenna Safety

Install a dipole in the attic they said.



It will be easy they said.

Wire Directly on Roof



Under Eave Inverted Vee



Under an Overhang

Beware of metal flashing inside of the stucco

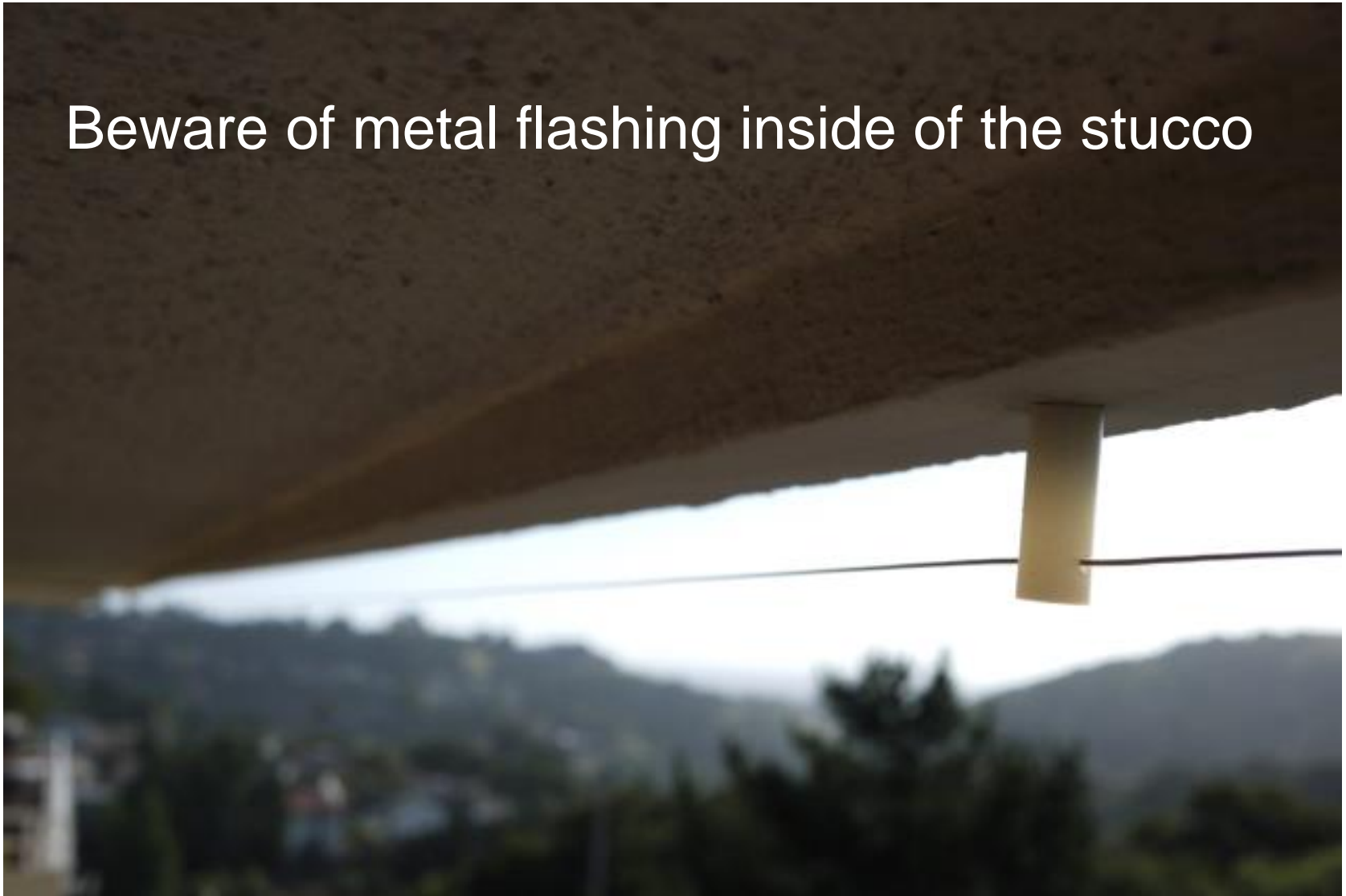

Commercially Available Folded Dipole

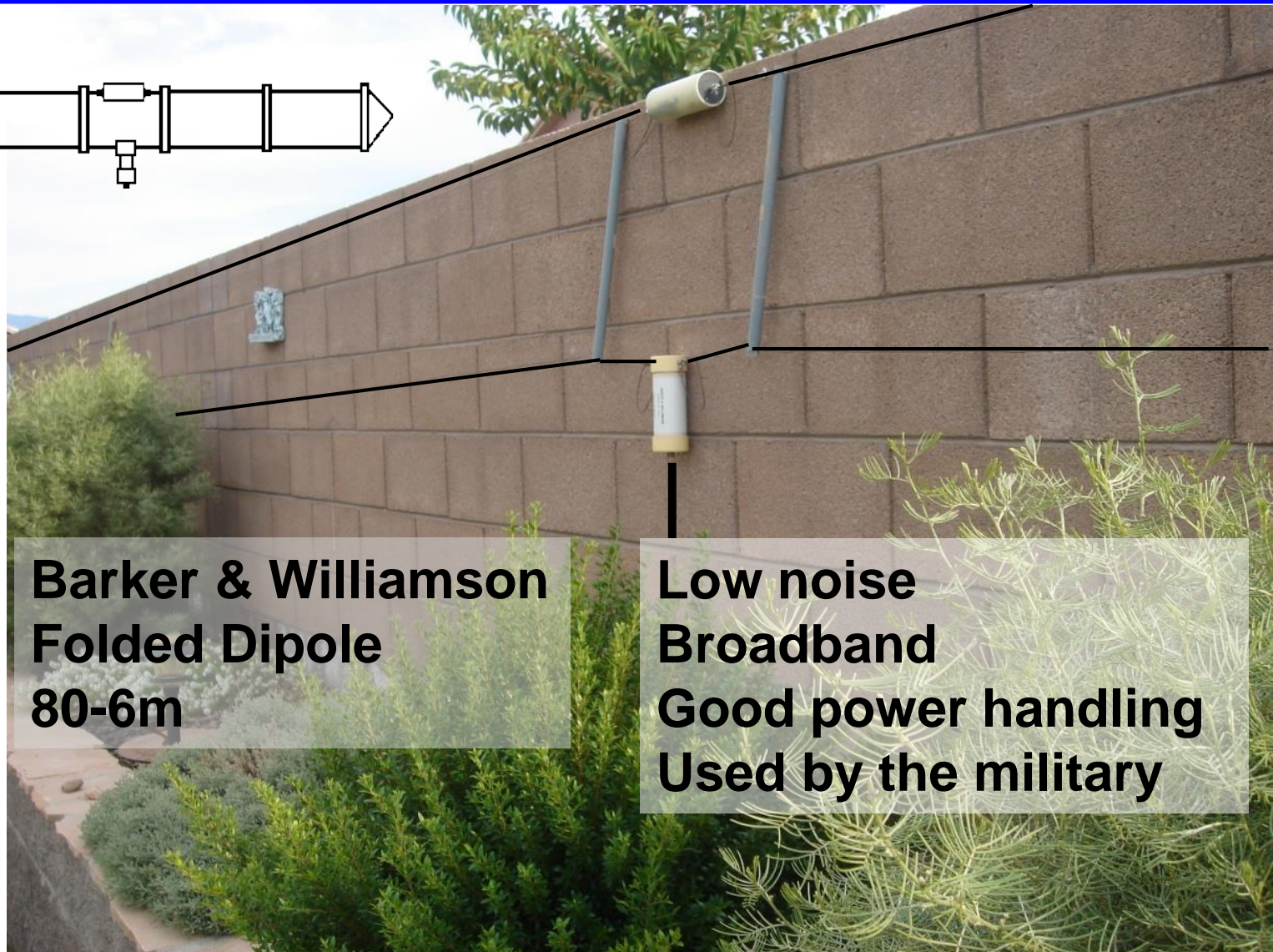
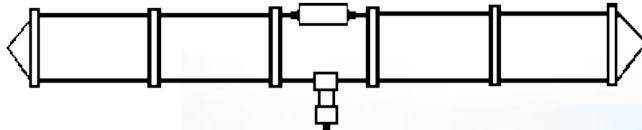

**Barker & Williamson
Folded Dipole
80-6m**

**Low noise
Broadband
Good power handling
Used by the military**

Palm Tree Antenna



Mobile Antennas

- Mobile antennas will provide good results in confined areas
- Made by Hustler and Hot Stick
- Require a counterpoise



Rain Gutter Antennas



The large effective conductor size increases the antenna bandwidth



Loop Antenna on a Flat Roof

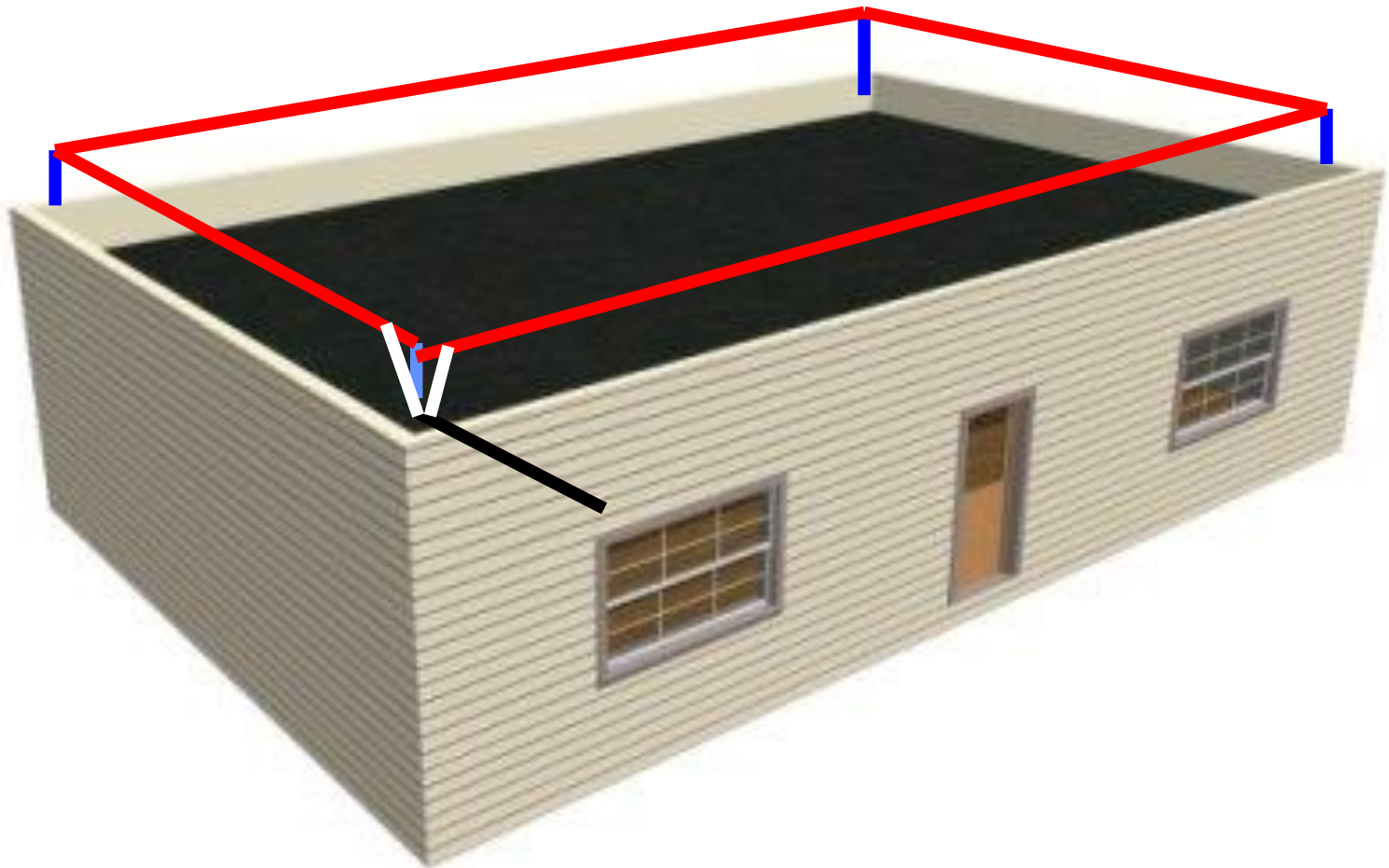

Spiderbeam Camouflage



An OCF Dipole for 40, 20, 10, and 6 Meters

- **Off-center Fed (OCF) antennas are much less sensitive to wire diameter than a half-wave dipole.**
- **The feed point impedance is approximately 200 ohms, which is matched using a 4:1 balun**

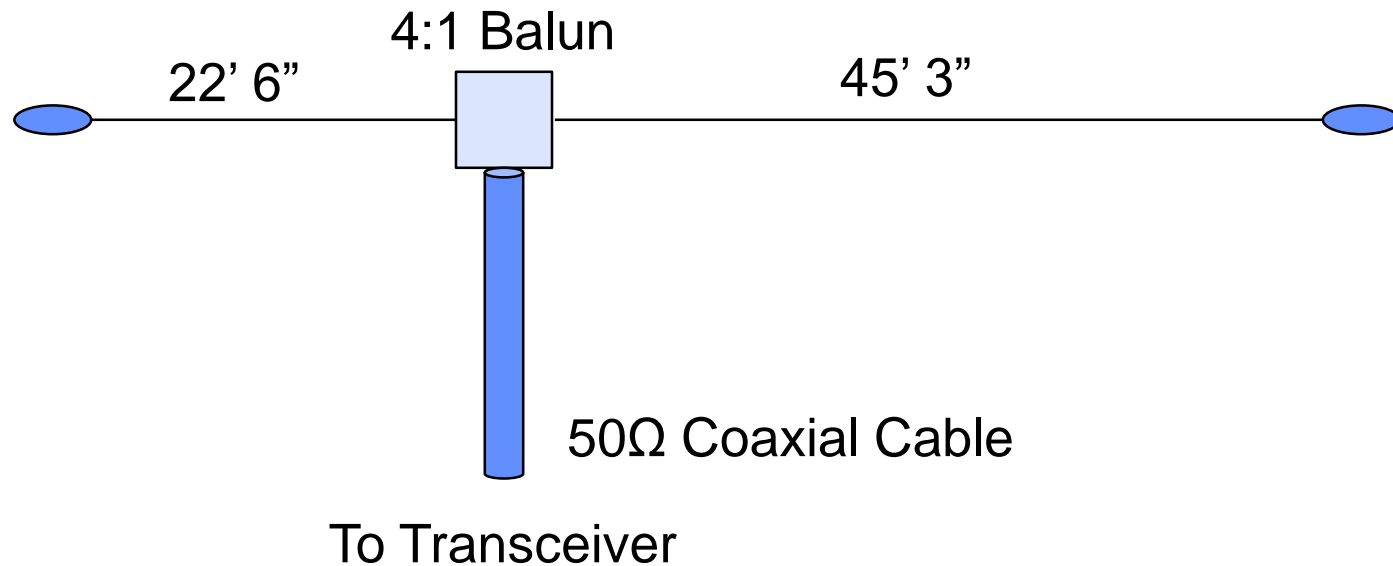

Prototype 40-meter OCF Dipole Parts

- Built by Gary KT7AZ using a commercially available balun and silver plated wire that is used for stringing pearls.



RBA-4:1 Balun is around \$30 and available at HRO, DX Engineering, GigaParts



Wire is available at Michael's, Hobby Lobby, and bead stores

Building the OCF Antenna

- This version is designed for portable use
- The two elements are wound on wooden boards
- The balun is mounted on a board that can be hung using nylon rope in the upper holes
- The lower holes are for coaxial cable strain relief

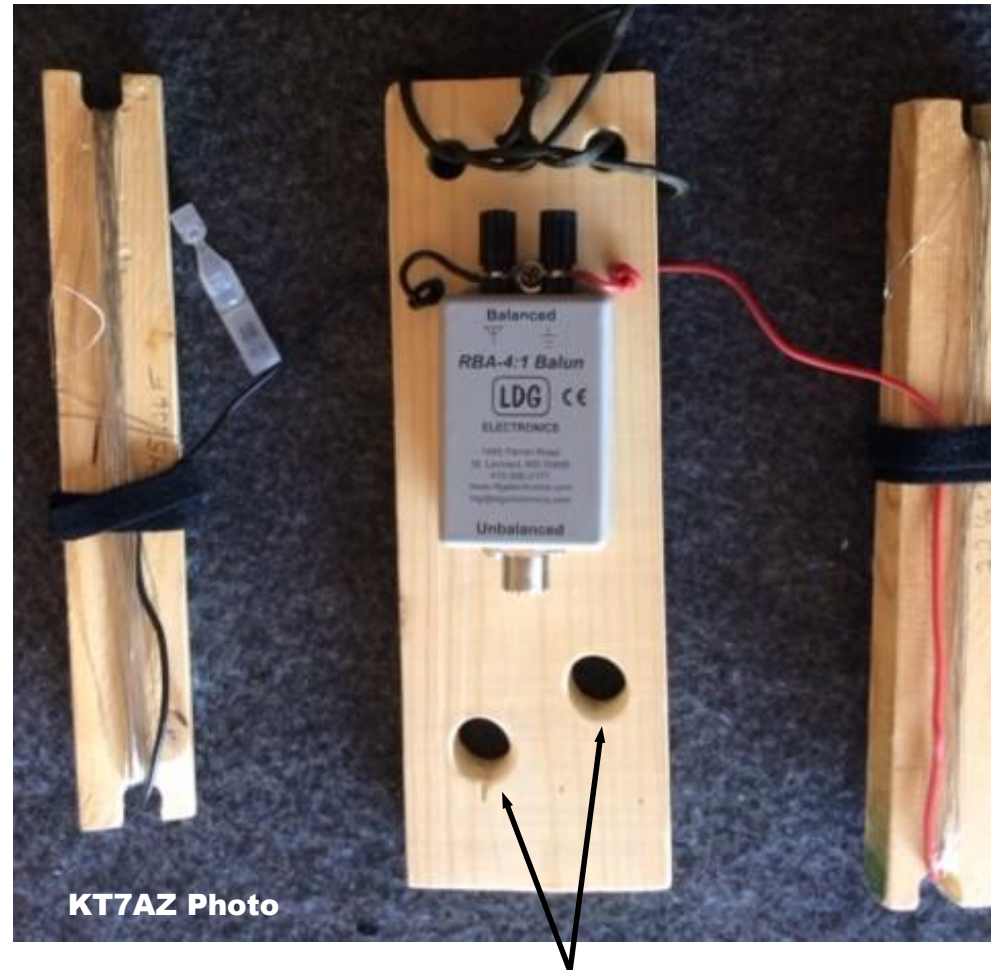

Cable runs through holes for strain relief

OCF Details

- **Heavier wire is used near the balun to minimize the bending stresses on the thin wire.**

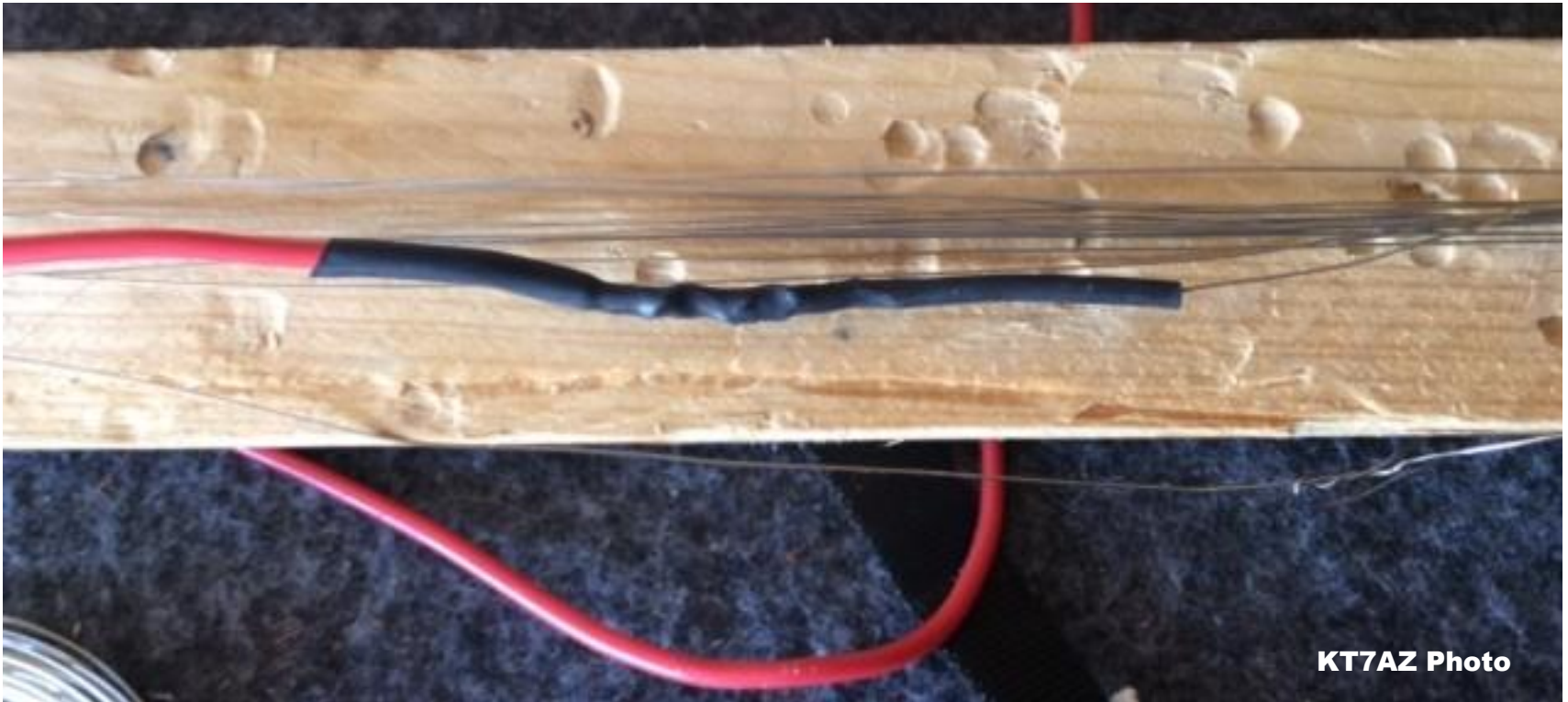

OCF Antenna Installation

- Here is the OCF dipole installed on a tower.
- A tree or small pole would work as well

The 26-gauge wire is difficult to see



OCF Dipole Performance

- The 40-meter antenna will give good performance on multiple bands.
- This antenna will work without a tuner on 40, 20, 10, and 6 meters without a tuner.
- A tuner would bring the VSWR below 2:1 on 20 meters



Birdhouse

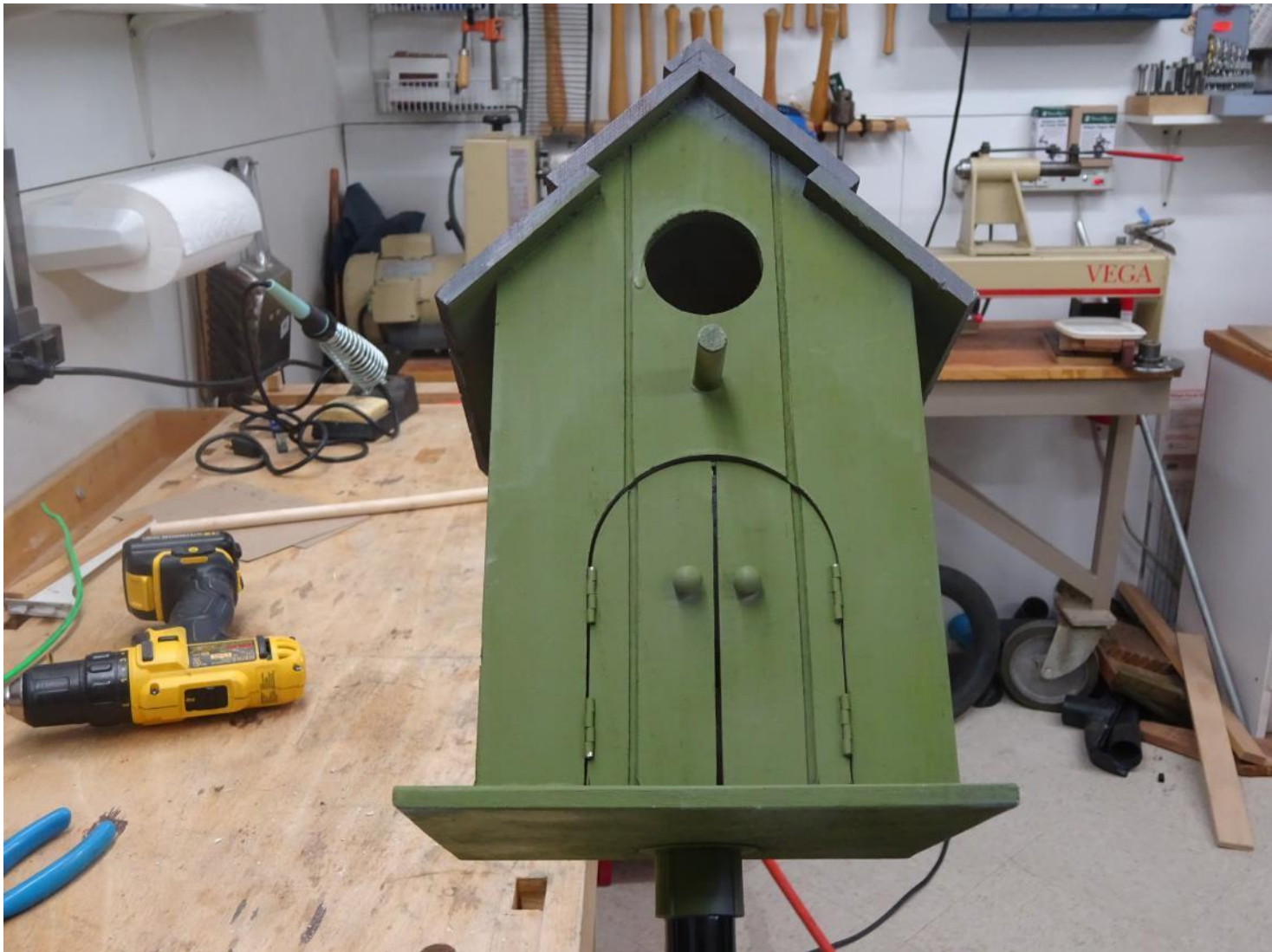

Birdhouse with Balun



Birdhouse in the Yard

Unfinished birdhouse
is \$12.00 at Michaels



Birdhouse “Guy Wire” Attachment

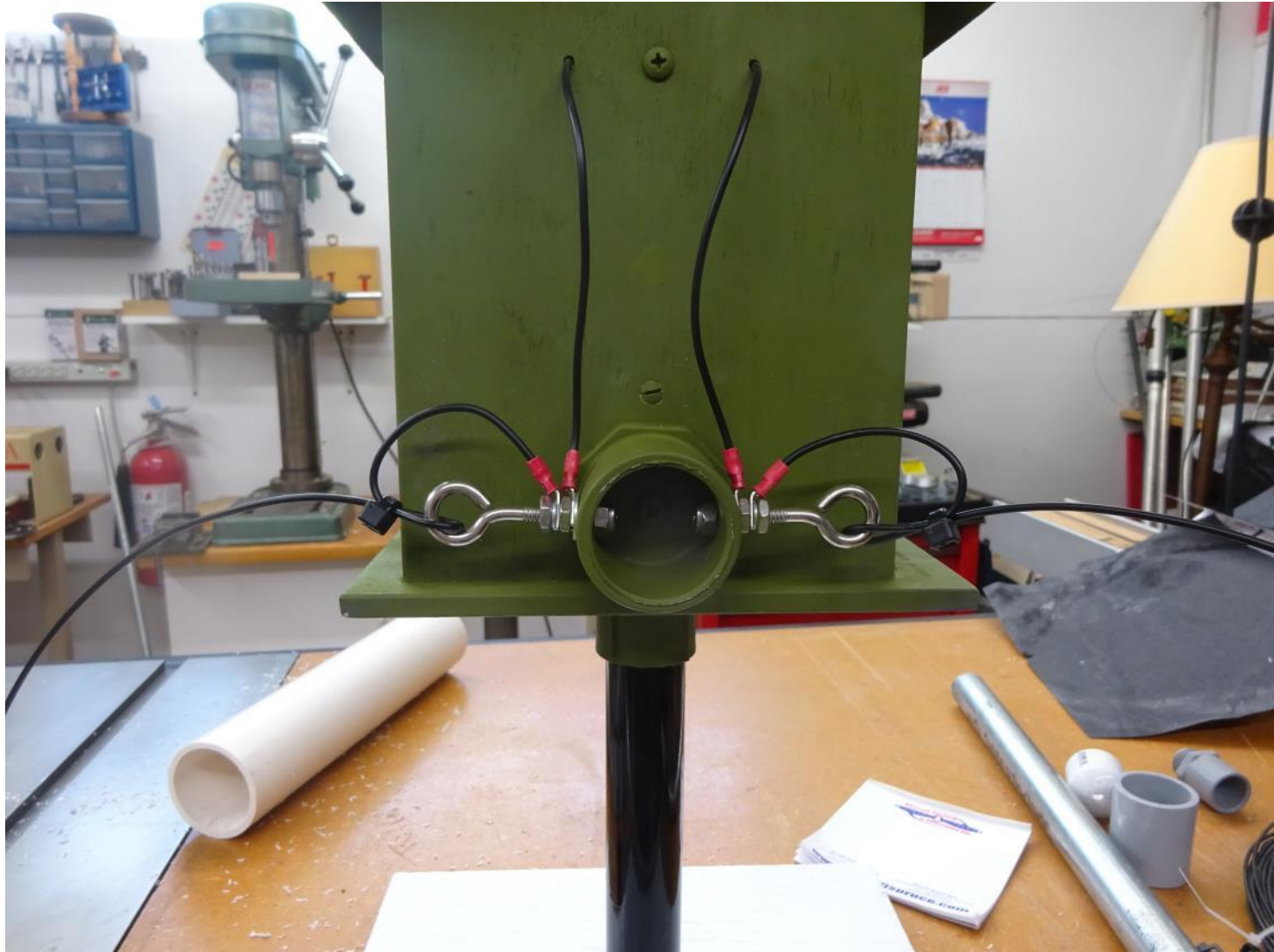

Hustler 4-BTV

- **The Hustler 4-BTV (4 Band Trap Vertical) can be sleeved**
- **The outer diameter of the plastic trap caps is exactly 2 inches**
- **A 2-inch PVC pipe will fit over the traps, but not over the clamps**
- **The 2-inch sleeve can be made in sections with cutouts to accommodate the clamps**

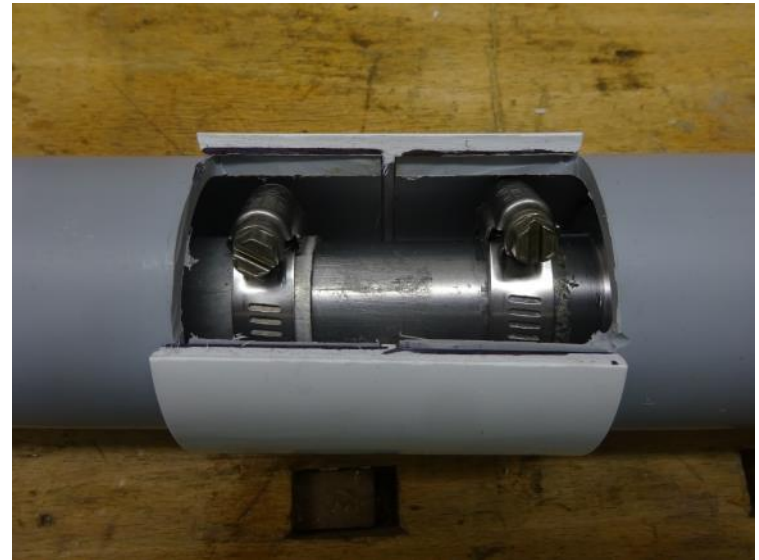

4-BTV Sleeve

- The sleeve can be decorated with fake foliage
- OR
- The antenna itself can be painted after it is tuned



Power Considerations

- **Almost any wire will handle 100 watts**
- **One way to make up for low antenna gain is with more transmitter power (lots more)**
- **The feedpoint impedance of a resonant dipole is approximately 72 ohms.**
- **At 1500 watts the feedpoint RF current is 4.5 amps**
- **At 14 MHz the skin depth of the RF on a copper wire is 0.0007 inches**
- **This means that a 14-gauge wire has an effective cross sectional area of a 28-gauge wire**
- **The 14 gauge wire does not fuse because of the overall thermal mass of the wire**
- **A 24-gauge wire may fuse with 1500 watts running RTTY, but will be OK running SSB**

Feed Point Current

- Feed point current of an antenna increases as the square root of power

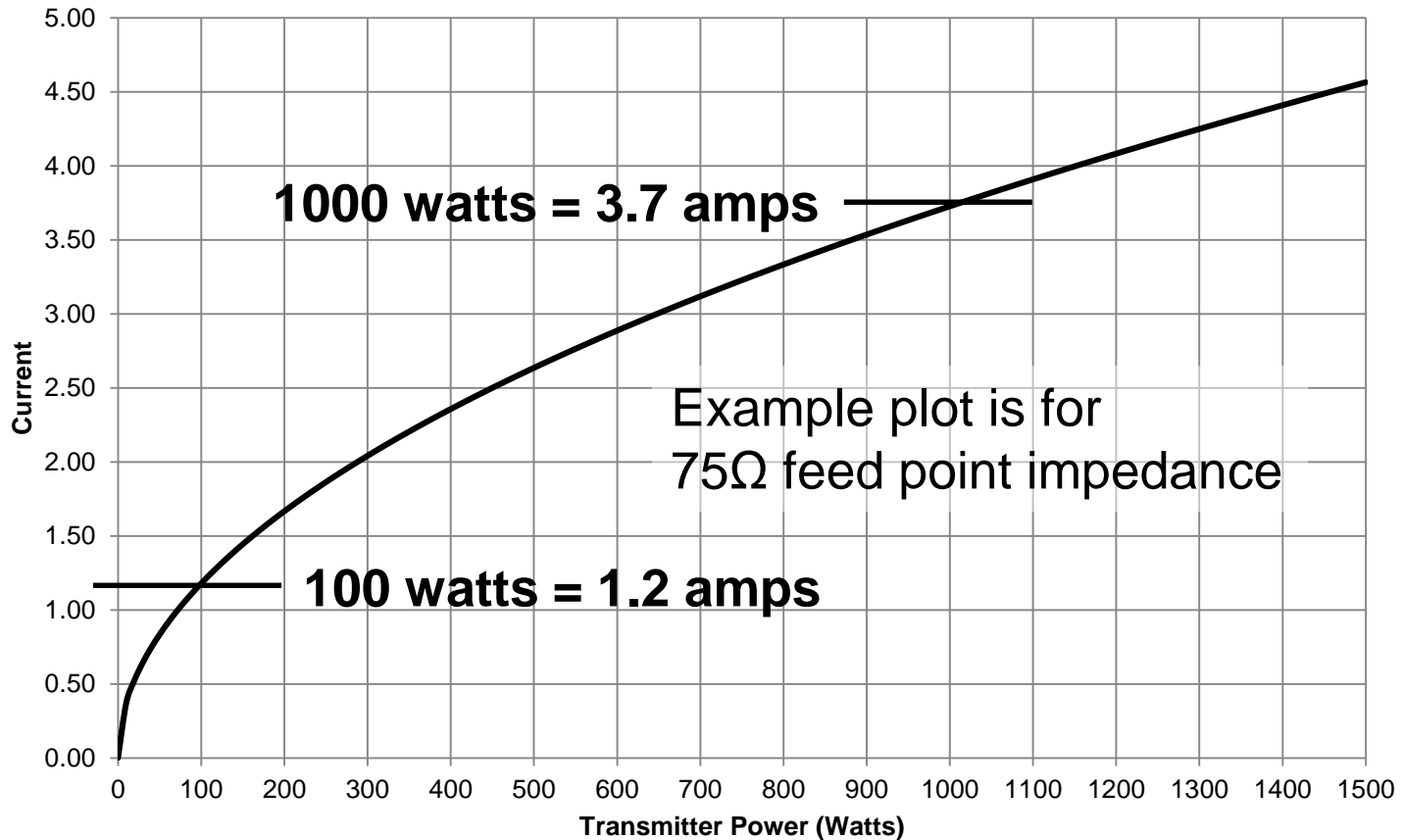

Transmitter Power Consideration

- **Stealth antennas usually have lower gain than full-size Yagis.**
- **Stealth wire antennas, however, often have the same gain as non-stealth wire antennas.**
 - **160 meters (1.8 MHz) through 30 meters(10 MHz)**
- **Running maximum legal power (1500 watts PEP) will overcome lower antenna gain relative to big antennas on the higher bands.**
 - **20 meters (14 MHz) through 10 meters (30 MHz)**

Antenna Analyzer

- Making antennas out of downspouts, fences, and other items will be easier with an antenna analyzer.
- Knowing the feed point impedance will guide the designer to tune a stealthy antenna



AIM 4170 Plot of a 20-m Vertical

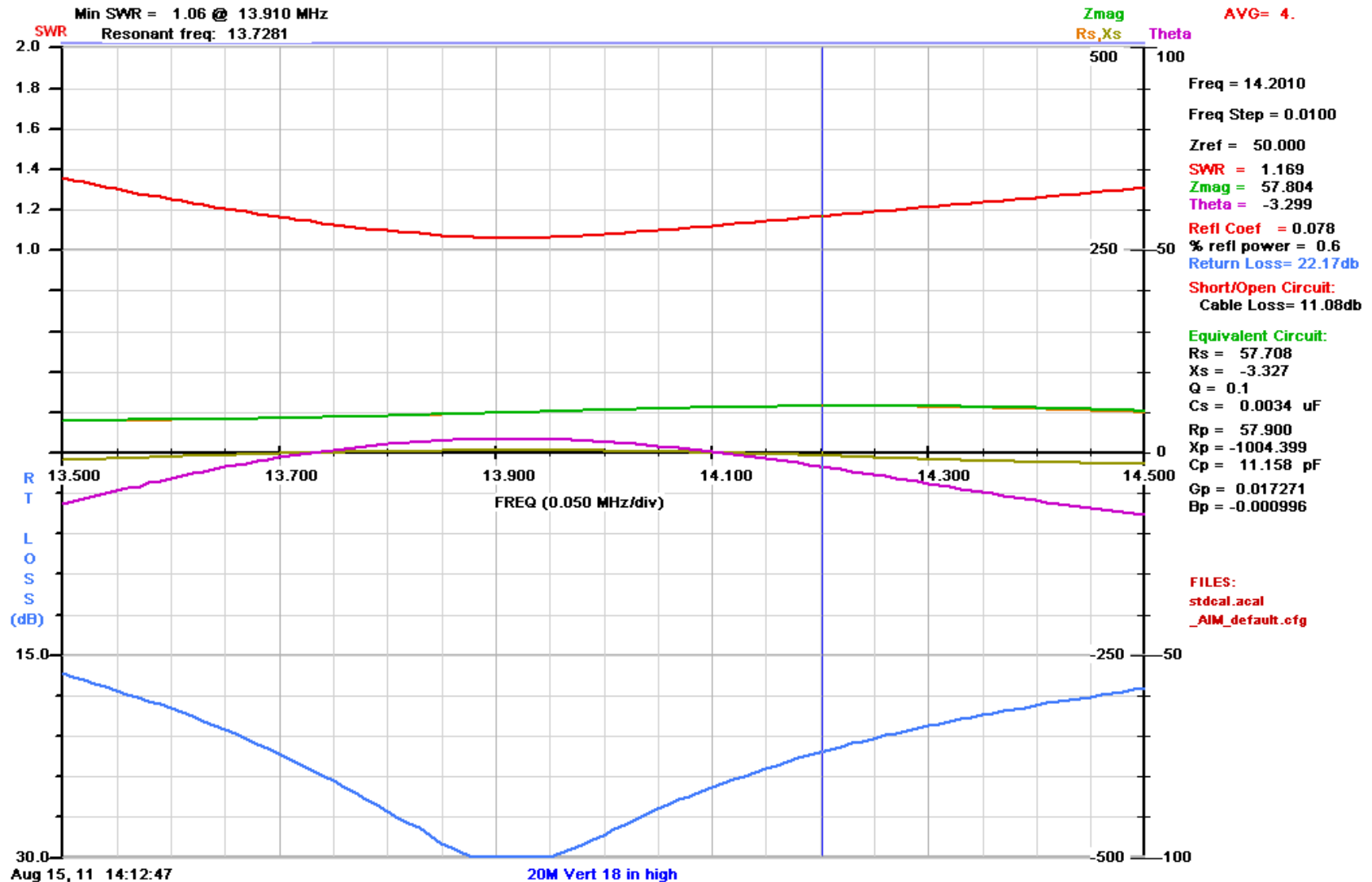

AIM 4170 Plot of an 80-meter OCF Dipole

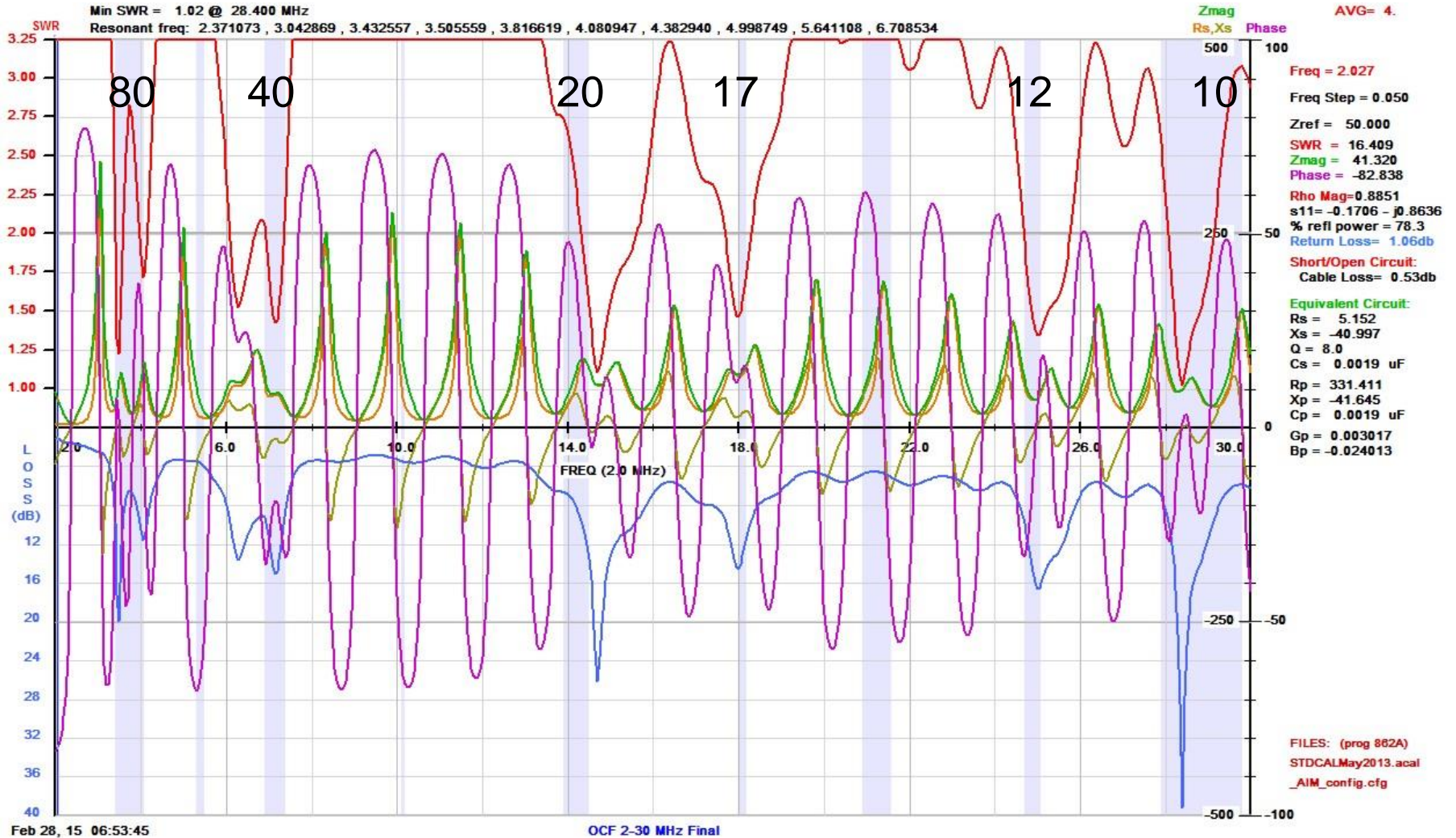

Antenna Tuner

- **Many stealth antennas will not have a feed point impedance anywhere near 50 Ω**
- **An antenna tuner will usually match antenna feed point impedances from 20 Ω to 1500 Ω**
- **Usually configured as an L-network**
- **Note that the L-network that most tuners use is a high-pass filter**
 - **The transmitted signal going into the tuner must be clean**
 - **The antenna tuner must not have any broken or marginal connections that will generate harmonics**

Manual Antenna Tuner



This is a 600-watt model

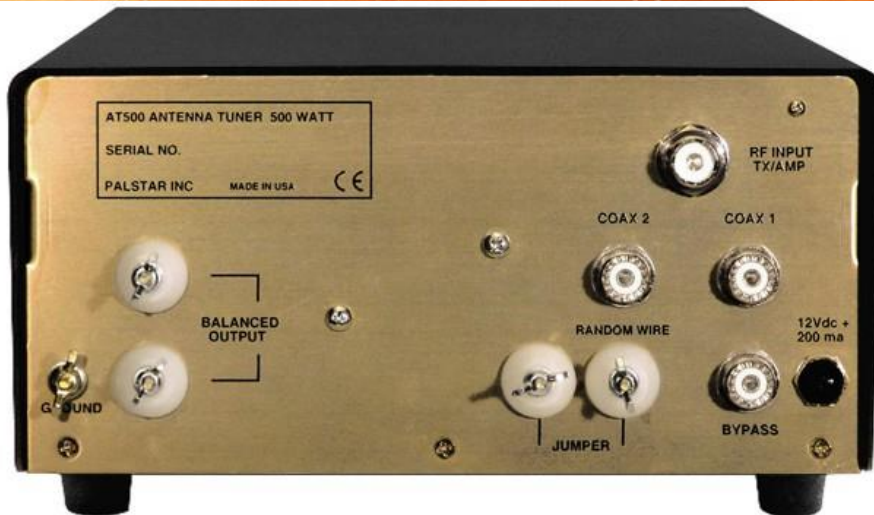

Automatic Antenna Tuner



- Automatic antenna tuners usually connect to the transceiver
- The tuner manufacturer has cables for the popular transceivers

MFJ-998 1500 watt model

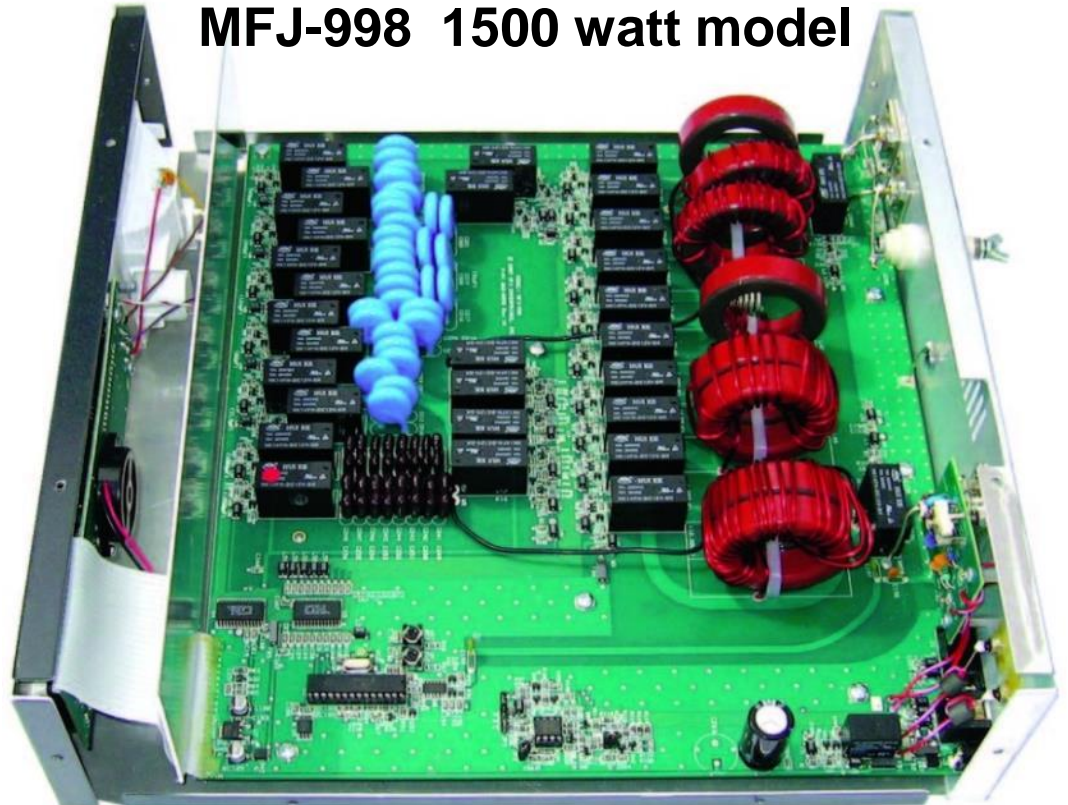

Longer is Better (Usually)

- A very short antenna has low radiation resistance and very high capacitive reactance, which is difficult to match even with a tuner.

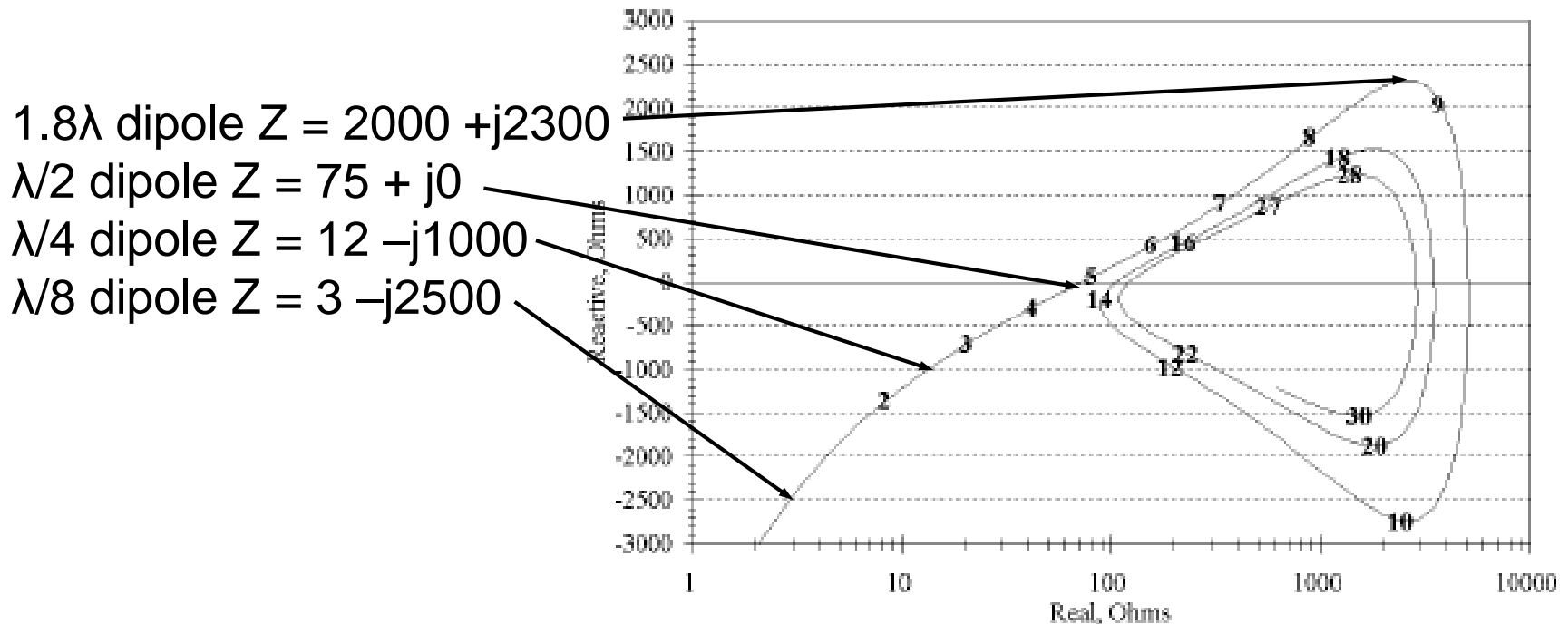

Feed-point impedance versus frequency for a theoretical 100-foot long dipole in free space, fed in the center and made of extremely thin 0.001-inch diameter wire. (Source: ARRL Antenna Book)

Safety Considerations

- The antenna ends can have over 1kV of RF voltage
- Make sure no one can touch the antenna while you are transmitting
- If people can get close to your antenna, then you should conduct an RF exposure study
- The basic exposure limit for HF is 180 milliwatts per square foot averaged over 30 minutes
- Suggested reading: *RF Exposure and You*
 - by Ed Hare, W1RFI
 - Available from ARRL

Expensive Stealth Antenna

Larson Company
Camouflage
Tucson AZ



Other Options

**Vertical dipole is
broadband if several
wires are used**

LTA Inflatable Antenna



Array Solutions Flagpole Antenna

- **Vertical Dipole**
- **Does not require ground radials**
- **Several Heights**
 - **12 feet**
 - **16 feet**
 - **20 feet**
 - **28 feet**



Array Solutions Flagpole Specs

Specifications				
	12 foot	16 foot	20 foot	28 foot**
Tunable Frequency Range*, approx	3 MHz – 54 MHz	3 MHz – 54 MHz	3 MHz – 30 MHz	3 MHz – 30 MHz
Gain Range***, dBi, over average ground	-0.4 (at 14 MHz) to 4.2 dBi (at 54 MHz)	-1.22 (at 10 MHz) to 4.2 (at 44 MHz)	-1.32 (at 7 MHz) to 4.21 (at 30 MHz)	0.48 (at 3 MHz) to 4.5 (at 30 MHz)
Gain angle from horizontal (of max radiation)	28° (at 14 MHz) to 16° (at 54 MHz)	28° (at 10 MHz) to 47° (at 44 MHz)	27° (at 7 MHz) to 17° (at 30 MHz)	26° (at 3 MHz) to 13° (at 30 MHz)
Impedance	50 Ω			
Polarization	Vertical			
Power Rating	Dependant on the power rating of your Tuner selection			
RF Calculation Software	EZNEC Pro/4 v. 6.0.8, NEC 4 D calculation engine			
Connector	PL-259			
Est Weight	15 lb	18 lb	20 lb	40 lb
Overall Dimensions	12 feet above ground, 3 feet below	16 feet above ground, 3 feet below	20 feet above ground, 3 feet below	28 feet above ground, 3 feet below
Tubing diameters	2" OD throughout	2" OD throughout	2" OD throughout	2" top, tapering to 3" OD base
Wind Survival Rating	100 mph	100 mph	90 mph	90 mph
Materials	6063-T832 aluminum, 304 stainless fasteners, fiberglass insulators			
Mechanical Design Standard	FP 1001-07 Guide Specifications For Design Of Metal Flagpoles			
Shipping Dimensions	54" x 11" x 9"	54" x 11" x 9"	85" x 11" x 9"	85" x 11" x 9"
Shipping Weight	20 lb	22 lb	25 lb	43 lb
Ordering Options	With flag kit – DXFP. Without flag kit – DXV (DX Vertical-Dipole)			

Optimal Flagpole Antenna Setup

- Suggested flagpole antenna connection
- Placing the tuner near the antenna base reduces VSWR induced coaxial cable loss
- The 1:1 balun keeps antenna current off of the feedline

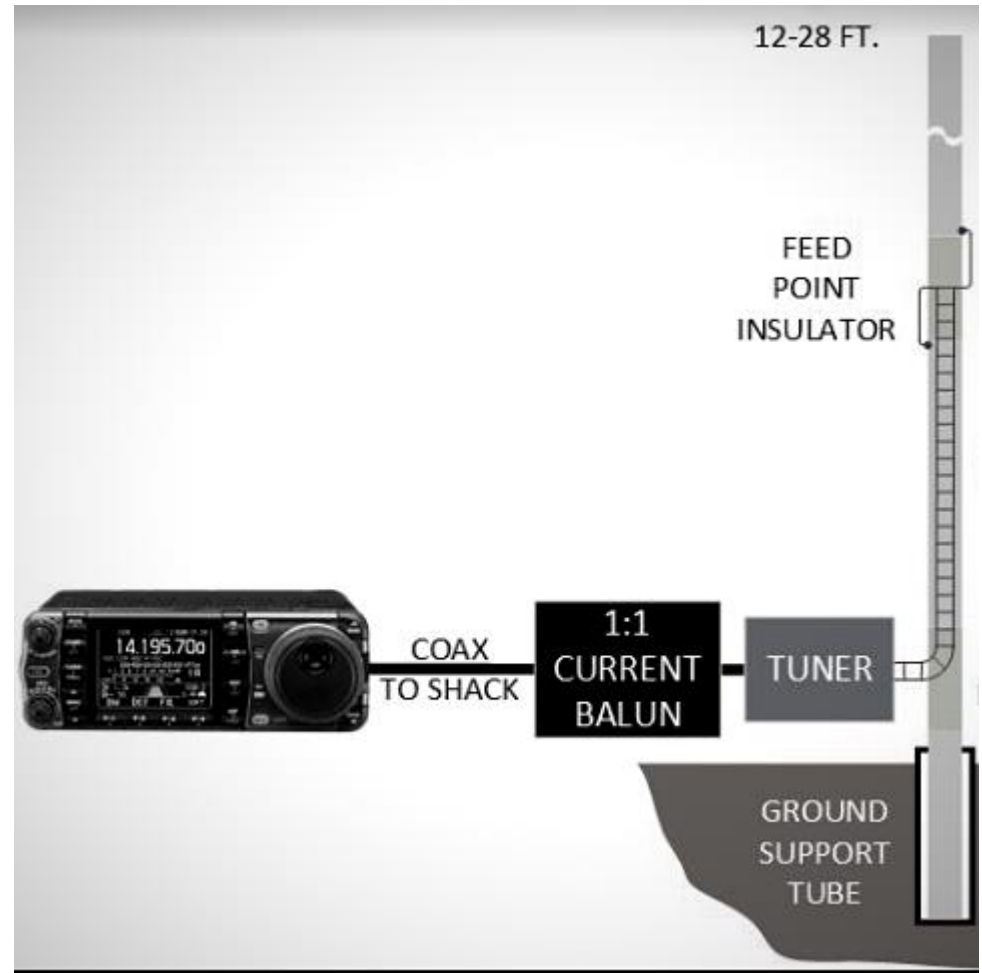

Image © Array Solutions
Used with permission

Zero-Five Flagpole Antennas



- **Left: 24-foot**
 - 7 MHz to 54 MHz
- **Right: 20-foot**
 - 10 MHz to 54 MHz
- **Requires radials**
- **New construction or a large yard to bury radials**



Photographs
© ZeroFive-Antennas
Used with permission

Zero-Five Flagpole Installation

- Dig a 40-inch (102 cm) deep by 12-inch (305 cm) hole
- Assemble the rebar base and suspend it in the hole
- Add cement, wait for it to harden
- Attach flagpole and coaxial cable
- Decorate and buy a flag
- Radials will improve performance



Photographs
© ZeroFive-Antennas
Used with permission

N6BT Bravo EV-5A Antenna

- **Tom Schiller N6BT**
- **Designer of the Force 12 Antennas.**
- **Next generation of antennas that are great for HOAs.**
- **Less than 9 feet tall**
- **Low profile, high efficiency**
- **5-band, remote-switched**
- **20-10m and 6m**



N6BT new antennas

- N6BT has a new antenna
- FP-1 Flower Power
- Operates on 20, 17 and 15m
 - Remote band change or manual; only a bit over 7' tall
 - It was demonstrated at the ARRL Southwestern Division Convention and it worked well.
- Cactus and Dolphin metal sculpted antennas are being designed.
- <http://www.n6bt.com/>



Moveable Antennas

- **Stealth can mean “now you see it; now you don’t”**
- **Set out in a yard when in use and remove it when done.**
- **“What antenna?”**
- **Flat grey paint helps hide it even when it is out.**



EV-5K in a Tripod and Bucket

Loop Antennas

- **Loop antennas are small and can be mounted near the ground**
- **MFJ has a 100-watt loop antenna that is relatively small and can be hidden or camouflaged**



Homemade HF Loop Antenna

- **Copper refrigeration coil, copper pipe, or copper strapping**
- **Make tight connections**
- **Gamma Match**
- **Tuning is narrow band**
- **Good signal rejection broadside to the loop**
- **Must be re-tuned for significant frequency change**

Loop Optimized for 60 Meters

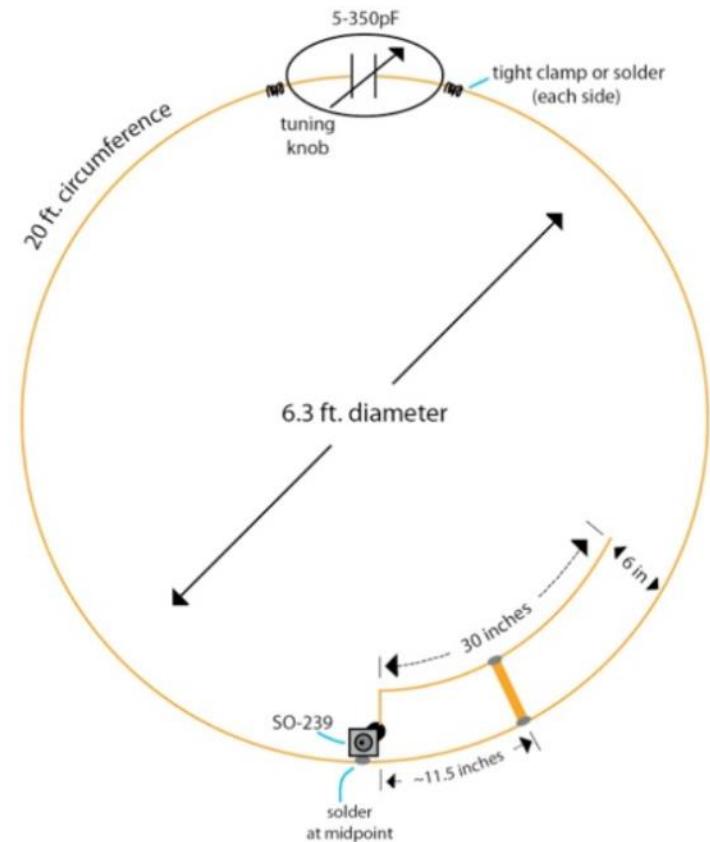

Optimized Loop Antenna

Band	Frequency (MHz)	Wavelength (feet)	Circumference (feet)	Diameter (feet)
160	1.85	532.1	53.2	16.9
80	3.6	273.4	27.3	8.7
60	5	196.9	19.7	6.3
40	7.125	138.1	13.8	4.4
20	14.175	69.4	6.9	2.2

Homebrew Loop Centered on 60 Meters

- **Tuning Capacitor**
 - Variable
 - High Voltage
 - Vacuum variable
 - Wide spaced conventional
- **Gamma Match**
- **Power handling is a function of the tuning capacitor RF voltage rating**
- **Will tune 80 and 40 meters as well**

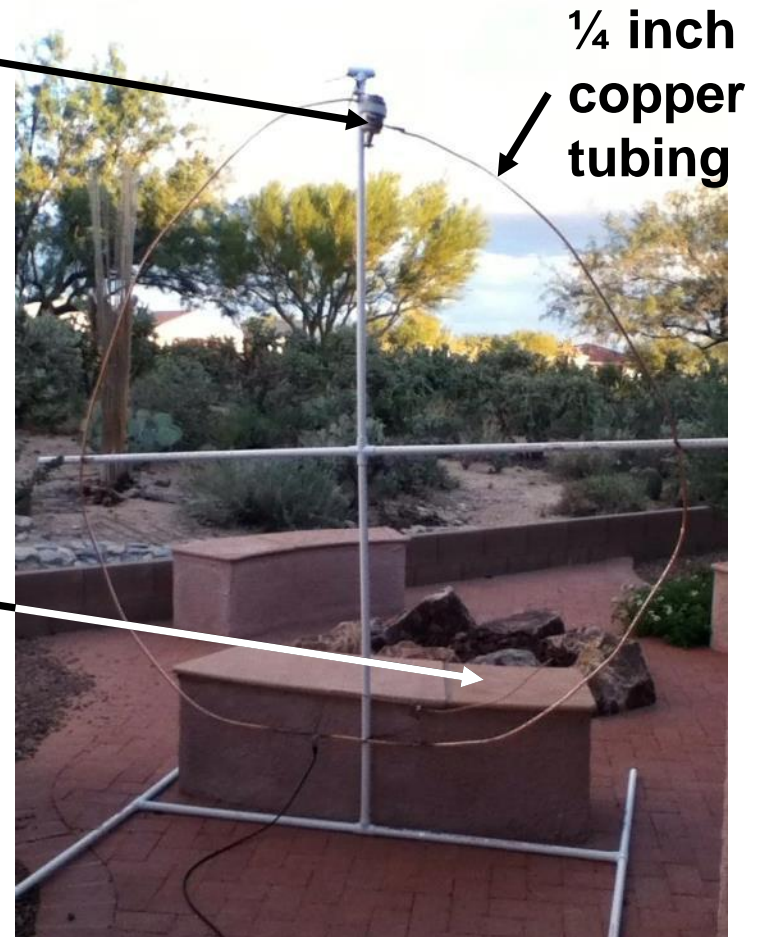

160 Meter Vertical Dipole Antenna

- 160 meters is a nighttime band
- Party supply stores carry 3-foot balloons for \$7 each.
- Three balloons will lift a 270 foot 160-meter half-wave element using #20 enameled wire
- Feeding a $\frac{1}{2}$ wave element with a $\frac{1}{4}$ wave ladder line match requires about 9 balloons

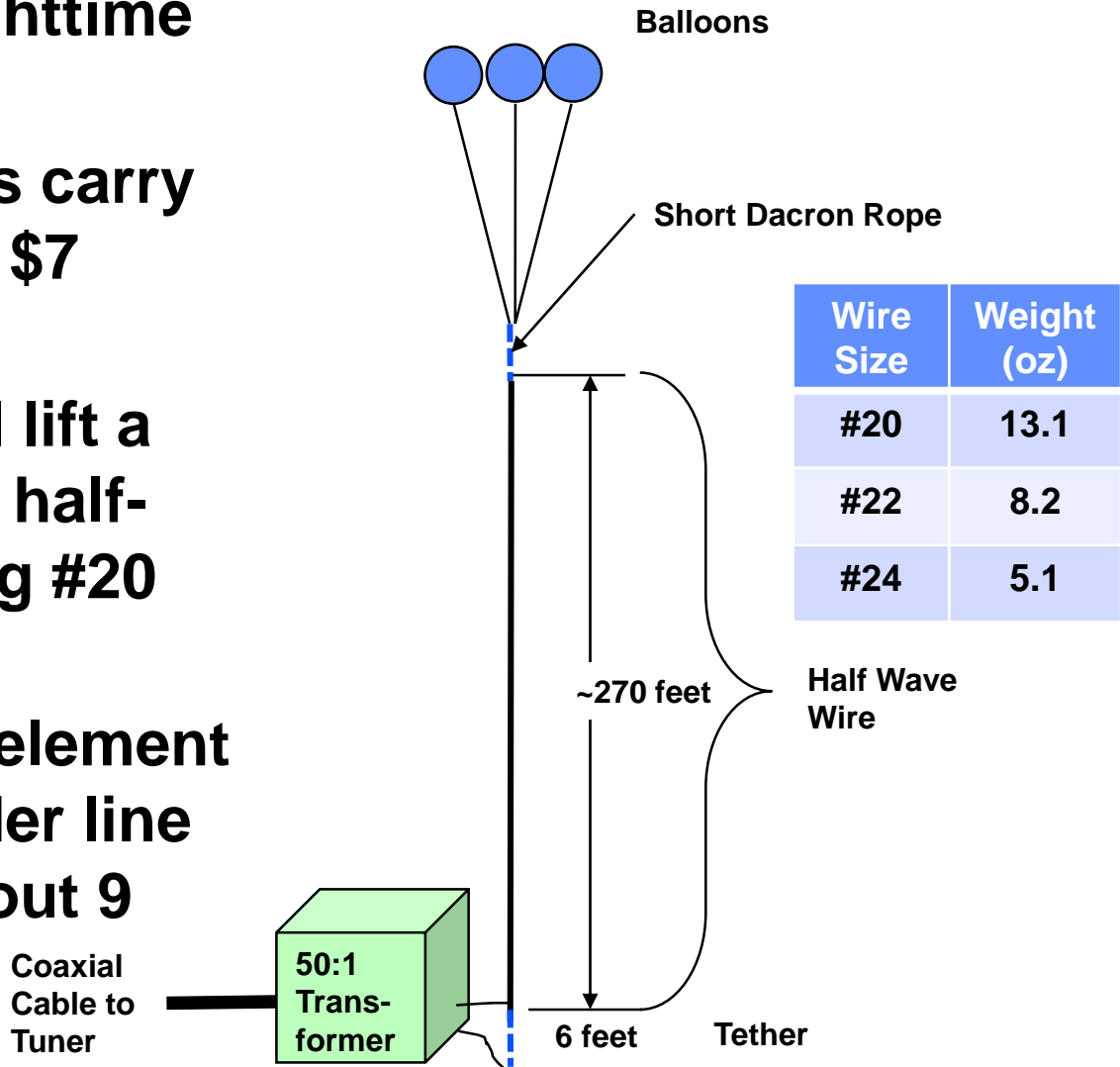

Balloon Information

Balloon Type		Inflated Diameter	Weight Needed to Hold Down One Balloon	Lift Ability	Gas Capacity	Average # per 242 Cu. Ft. Tank	Average Float Time	Float Time with Ultra Hi-Float™
11"	Round Latex Standard and Special Tone Colors	11"	12 grams	.35 oz. (10g)	.5 cu. ft.	484	18 - 24 Hours	1 - 4 Weeks
11"	Round Latex Metallic and Decorator Tone Colors	11"	12 grams	.35 oz. (10g)	.5 cu. ft.	484	16 - 18 Hours	1 - 3 Weeks
16"	Round Latex	16"	36 grams	1.2 oz. (34g)	1.5 cu. ft.	160	30+ Hours	3 - 7 Weeks
16"	Geo Donut®	16"	16 grams	.5 oz. (14g)	.7 cu. ft.	345	22 - 26 Hours	4 - 12 Days
16"	Geo Blossom®	16"	13 grams	.4 oz. (11g)	.6 cu. ft.	403	18 - 24 Hours	3 - 10 Days
30"	Latex	30"	186 grams	6.5 oz. (184g)	8 cu. ft.	30	3 - 5 Days	3 - 10 Days
3'	Round Latex	2.5' 3.0'	185 grams 341 grams	6.5 oz. (184g) 12 oz. (339g)	8 cu. ft. 15 cu. ft.	30 16	3 - 5 Days 3 - 5 Days	6 - 20 Weeks
646	Latex	6"	12 grams	.35 oz. (10g)	1 cu. ft.	242	12 Hours	1 - 3 Days
4'	Chloroprene	4'	2 lbs.	1.7 lb. (771g)	34 cu. ft.	7	4 - 5 Days	-
5.5'	Chloroprene	5.5'	5 lb.	4.7 lb. (2.13kg)	66 cu. ft.	4	8 Days	-
8'	Chloroprene	8'	16 lbs.	15.5 lb. (7.03kg)	267 cu. ft.	<1	18 Days	-

Conclusion

- **With the right supplies, equipment, and ingenuity you can make effective stealth antennas.**
- **There are commercially available stealth antennas.**
- **Stealth may mean antennas that can be put up and taken down to avoid detection.**
- **Thanks to Tom Fagan, K7DF, for some of the pictures used in this presentation.**
- **Thanks to Gary Schmitz, KT7AZ, for the information on the 40/20/10/6-meter OCF dipole**
- **Thanks to George, NG7A, for the HF loop antenna information**